

DESCRIPTION OF THE CATALOGUE VERSION

All the motors are manufactured in Quality Assurance System consistent with ISO 9001.

Application:	general industrial
Duty:	S1
Degree of protection:	IP 55
Rated voltage:	230 V
Frequency:	50 Hz
Ambient temperature:	from -15°C to + 40°C
Mounting height:	up to 1000 m above sea level
Insulation class:	F



DESCRIPTION OF THE CUSTOMIZED VERSION

The motors covered by the present catalogue comply with the regulations and standard effective in other countries, consistent with IEC standards.

Other supply voltage	
Frequency:	60 Hz
Degree of protection:	IP 56
Insulation class:	H
Tropicalization	
Other duty type	
Other versions per customer's specifications	



BEARINGS

All the motors described in the present catalogue are provided with CE mark. It means that our products are consistent with the European Union directives regarding the safety measures.

Frame size	DE Bearing	NDE Bearing
SE(M)g 56	6201 2Z	6201 2Z
SE(M)g 63	6202 2Z	6202 2Z
SE(M)h 71	6203 2Z	6203 2Z
SE(M)h 80	6204 2Z	6204 2Z
SE(M)h 90	6205 2Z	6204 2Z

MECHANICAL DESIGN

The frame, bearing shields, feet and terminal box are AK11 aluminium alloy cast. The fan is made of thermoplastic material, the fan cover is made of steel. Squirrel cages of standard starting torque motors are A1 aluminium cast, the rotors for increased starting torque are special aluminium alloy cast AK 121 (siluminum).

FEATURES

Single phase motors are manufactured within the range of frame size 56-90 as:

- motors with standard starting torque (with capacitor run),
- motors with increased starting torque (with capacitor run and specially adjusted parameters),
- motors with high starting torque (with capacitor run, capacitor start and centrifugal switch).

ORDER DATA



When placing an order, the following motor data should be given:
full motor type designation,
rated output,
rated speed,
operation duty,
voltage and frequency,
mounting arrangement,
degree of protection,
any special requirements.

As part of our development program, we reserve the right to alter or amend any of the specifications without giving prior notice.

BASIC CONNECTION DIAGRAMS

1. With capacitor run

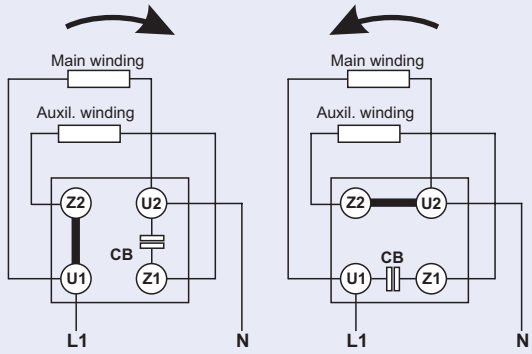

CB - capacitor run

2. With capacitors start / run

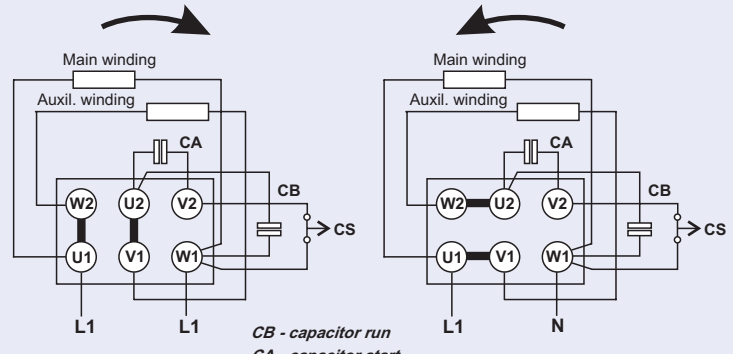

CB - capacitor run
CA - capacitor start
CS - centrifugal switch



OVERLOAD PROTECTION SETTINGS

Motor type	Maximal current at no load operation of the motor at: 230V; 50Hz	Rated current given on the motor name plate at: 230V; 50Hz	Maximal current at the rated load at: 230V; 50Hz	Recommended setting of the current for the overload protection of the motor at: 230V; 50Hz
	I_0 (max) [A]	I_N [A]	I_N (max) [A]	I_{NP} [A]
SEg 56-2A	0,75	0,85	1	1,1
SEg 56-2B	0,8	1	1,12	1,2
SEMg 56-2A	0,8	0,7	0,86	1
SEMg 56-2B	0,95	1	1,38	1,45
SEMg 56-2C	1,15	1,15	1,36	1,4
SEg 56-4A	0,54	0,53	0,62	0,65
SEg 56-4B	0,76	0,85	0,94	1
SEMg 56-4A	0,55	0,5	0,6	0,65
SEMg 56-4B	0,8	0,73	0,93	1
SEMg 56-4C	1,2	1,1	1,2	1,25
SEg 63-2A	1,35	1,45	1,74	1,65
SEg 63-2B	1,8	1,8	1,98	2,05
SEg 63-2C	1,9	2,25	2,47	2,55
SEMg 63-2A	1,2	1,2	1,37	1,4
SEMg 63-2B	1,8	1,8	2,16	2,2
SEMg 63-2C	1,85	1,8	2,09	2,15
SEg 63-4A	1,05	1,05	1,23	1,3
SEg 63-4B	1,3	1,4	1,54	1,6
SEg 63-4C	1,65	1,7	1,9	1,95
SEMg 63-4A	0,95	0,95	1,12	1,2
SEMg 63-4B	1,3	1,25	1,38	1,45
SEMg 63-4C	1,7	1,72	2,05	2,1
SEh 71-2B	3,2	3,8	4,2	4,5
SEh 71-2C	2,1	4,9	5,33	5,6
SEMh 71-2B	2,8	3	3,26	3,6
SEMh 71-2C	2,2	3,6	3,97	4,3
SEh 71-4B	2,5	3,1	3,52	3,8
SEh 71-4C	3,3	4,2	4,64	5
SEMh 71-4B	2,6	2,6	2,7	2,75
SEMh 71-4C	2,7	3	3,4	3,7
SEh 80-2B	3,7	7	7,55	7,8
SEh 80-2C	3	9,1	9,75	11
SEh 80-4B	2,9	4,9	5,35	5,5
SEh 80-4C	5,4	7,2	7,75	8,3
SEMh 80-2B	4	5	5,41	5,6
SEMh 80-2C	5,2	7,2	7,6	7,7
SEMh 80-4B	3,3	3,9	4,27	4,4
SEMh 80-4C	4,9	5,6	6,2	6,3
SEh 90-2S	3,5	9	9,55	10
SEh 90-2L	4	13	13,3	13,6
SEMh 90-2S	3,5	8	8,41	8,8
SEMh 90-2L	3,7	10	11	11,5
SEh 90-4S	5,4	7,2	7,75	8,2
SEh 90-4L	5	9	9,6	10
SEMh 90-4S	4,9	5,6	6,2	6,6
SEMh 90-4L	5,8	7,8	8,5	8,9

Current values given in a column 3 are stated on the rating plates.

Column 4 presents the maximal current values that can occur with the rated load for the rated efficiency and power factor deviations according to the standards.

Column 5 covers the values recommended for the setting switches used by the customers for the overload protection of the motor.

Item	Motor Type	Rated Output P _N		Rated Speed n _N [rpm]	Full Load Current at 230V I _N [A]	Efficiency η [%]	Power Factor cos φ _N	Rated Torque T _N [Nm]	Locked Rotor Current I _L /I _N	Locked Rotor Torque T _L /T _N	Breakdown Torque T _b /T _N	Moment of Inertia J [kgm ²]	Capacitor Run C _B 450V [μF]	Capacitor Start C _A 450V [μF]	Weight IMB3 m [kg]
		[kW]	[HP]												
STANDARD STARTING TORQUE MOTORS															
1.	SEg 56-2A	0,09	0,12	2840	0,85	55	0,88	0,303	2,8	0,4	1,6	0,00007	3	-	3
2.	SEg 56-2B	0,12	0,17	2860	1	61	0,92	0,4	3,1	0,45	1,5	0,00009	5	-	3,5
3.	SEg 56-2C	0,18	0,25	2800	1,5	62	0,89	0,614	2,6	0,4	1,6	0,0001	6	-	3,9
4.	SEg 63-2A	0,18	0,25	2820	1,45	57	0,95	0,61	2,6	0,55	1,7	0,000175	8	-	3,8
5.	SEg 63-2B	0,25	0,33	2850	1,8	66	0,92	0,84	3,1	0,5	1,9	0,000235	10	-	4,4
6.	SEg 63-2C	0,37	0,5	2850	2,25	76	0,95	1,24	3,5	0,4	1,6	0,00031	12	-	5,2
7.	SEh 71-2B	0,55	0,75	2820	3,8	68	0,96	1,86	3	0,36	1,6	0,00053	14	-	6,3
8.	SEh 71-2C	0,75	1	2820	4,9	71	0,98	2,54	3	0,4	1,5	0,000691	25	-	7,7
9.	SEh 80-2B	1,1	1,5	2780	7	72	0,97	3,78	2,7	0,4	1,4	0,00111	25	-	9,8
10.	SEh 80-2C	1,5	2	2740	9,1	73	0,99	5,23	2,7	0,5	1,5	0,00142	40	-	11,8
11.	SEh 90-2S	1,5	2	2800	9	77	0,99	5,12	3,3	0,4	1,6	0,0012	40	-	12,4
12.	SEh 90-2L	2	2,8	2780	13	74	0,99	6,87	2,5	0,4	1,4	0,0016	50	-	15,2
INCREASED STARTING TORQUE MOTORS															
13.	SEMg 56-2A	0,06	0,08	2800	0,7	50	0,78	0,205	2,4	1	2,3	0,00007	3	-	3,1
14.	SEMg 56-2B	0,09	0,12	2790	1	45	0,8	0,308	2,8	1,1	2,2	0,00009	5	-	3,5
15.	SEMg 56-2C	0,12	0,17	2800	1,15	57	0,84	0,409	3	0,75	2	0,0001	5	-	3,9
16.	SEMg 63-2A	0,12	0,17	2750	1,2	52	0,86	0,417	2,4	0,9	1,9	0,000175	6	-	3,8
17.	SEMg 63-2B	0,18	0,25	2760	1,8	52	0,84	0,623	2,7	0,8	2	0,000235	8	-	4,4
18.	SEMg 63-2C	0,25	0,33	2800	1,8	65	0,95	0,853	3,1	0,7	2	0,00031	10	-	5,2
19.	SEmh 71-2B	0,37	0,5	2800	3	64	0,9	1,262	2,7	0,7	1,8	0,000536	12	-	6,3
20.	SEmh 71-2C	0,55	0,75	2780	3,6	70	0,98	1,889	3,2	0,65	1,6	0,000691	20	-	7,7
21.	SEmh 80-2B	0,75	1	2800	5	70	0,94	2,56	3,4	0,65	1,9	0,00111	25	-	9,7
22.	SEmh 80-2C	1,1	1,5	2800	7,2	71	0,95	3,75	3,5	0,6	1,8	0,00142	30	-	11,6
23.	SEmh 90-2S	1,1	1,5	2760	8	73	0,85	3,81	3,8	0,6	1,6	0,0012	30	-	12,4
24.	SEmh 90-2L	1,5	2	2700	10	70	0,99	5,31	2,5	0,6	1,4	0,0016	40	-	15,2
HIGH STARTING TORQUE MOTORS															
25.	SEg 63-2AF	0,18	0,25	2820	1,5	57	0,95	0,61	4	1,8	1,7	0,000175	8	25	4
26.	SEg 63-2BF	0,25	0,33	2850	1,85	66	0,94	0,838	4,1	1,9	1,9	0,000235	10	30	4,6
27.	SEg 63-2CF	0,37	0,5	2850	2,45	72	0,95	1,24	4,5	1,7	1,6	0,00031	12	40	5,4
28.	SEmh71-2BF	0,37	0,5	2800	3,1	62	0,88	1,26	3,7	1,9	1,9	0,000536	12	20	6,8
29.	SEh 71-2BF	0,55	0,75	2820	3,8	68	0,96	1,86	3,6	1,7	1,6	0,00053	14	25	6,5
30.	SEmh 71-2CF	0,55	0,75	2780	3,6	70	0,98	1,89	3,5	1,7	1,6	0,000691	20	30	8,2
31.	SEh 71-2CF	0,75	1	2820	4,9	71	0,98	2,54	4	1,7	1,5	0,000691	25	70	8,1
32.	SEmh 80-2BF	0,75	1	2800	5	70	0,94	2,56	3,7	1,9	1,9	0,00111	25	40	10,5
33.	SEh 80-2BF	1,1	1,5	2780	7	72	0,97	3,78	3,5	1,7	1,4	0,00111	25	70	10,6
34.	SEmh 80-2CF	1,1	1,5	2800	7	73	0,95	3,75	3,8	1,8	1,8	0,00142	30	50	12,8
35.	SEh 80-2CF	1,5	2	2800	9,5	75	0,96	5,12	3,7	1,9	1,7	0,00142	40	60	12,2
36.	SEh 90-2SF	1,5	2	2800	9	77	0,99	5,12	3,6	1,7	1,6	0,0012	40	60	13,5
37.	SEh 90-2LF	2	2,8	2780	13	74	0,99	6,87	3,5	1,6	1,4	0,0016	50	75	16,3

TECHNICAL DATA

TOTALLY ENCLOSED MOTORS IP 55

230 V

TECHNICAL DATA

Item	Motor Type	Rated Output P _N		Rated Speed n _N [rpm]	Full Load Current at 230V I _N [A]	Efficiency η [%]	Power Factor cos φ _N	Rated Torque T _N [Nm]	Locked Rotor Current I _L /I _N	Locked Rotor Torque T _L /T _N	Breakdown Torque T _b /T _N	Moment of Inertia J [kgm ²]	Capacitor Run C _B 450V [μF]	Capacitor Start C _A 450V [μF]	Weight IMB3 m [kg]
		[kW]	[HP]												
STANDARD STARTING TORQUE MOTORS															
38.	SEg 56-4A	0,06	0,08	1410	0,53	54	0,95	0,406	2	0,55	1,55	0,0002	3	-	3,1
39.	SEg 56-4B	0,09	0,12	1420	0,85	56	0,9	0,605	2,4	0,58	1,55	0,00025	4	-	3,5
40.	SEg 63-4A	0,12	0,17	1400	1,05	54	0,92	0,819	2,2	0,6	1,7	0,00024	6	-	3,7
41.	SEg 63-4B	0,18	0,25	1400	1,4	60	0,95	1,228	2,3	0,65	1,55	0,000307	8	-	4,3
42.	SEg 63-4C	0,25	0,33	1400	1,7	68	0,92	1,705	2,6	0,5	1,45	0,00038	10	-	5,1
43.	SEh 71-4B	0,37	0,5	1360	3,1	62	0,87	2,598	2	0,4	1,3	0,000852	10	-	6,3
44.	SEh 71-4C	0,55	0,75	1350	4,2	65	0,92	3,89	2,2	0,4	1,4	0,001099	18	-	6,3
45.	SEh 80-4B	0,75	1	1370	4,9	70	0,95	5,23	2,5	0,4	1,3	0,00208	20	-	9,6
46.	SEh 80-4C	1,1	1,5	1370	7,2	72	0,93	7,67	2,6	0,4	1,4	0,002652	30	-	11,4
47.	SEh 90-4S	1,1	1,5	1370	7,2	72	0,93	7,7	2,6	0,4	1,4	0,0024	30	-	12,3
48.	SEh 90-4L	1,3	1,8	1370	9	72	0,91	9,1	2,8	0,38	1,4	0,0032	40	-	14
INCREASED STARTING TORQUE MOTORS															
49.	SEMg 56-4A	0,04	0,06	1390	0,5	40	0,84	0,275	2	1,4	2,1	0,0002	3	-	3,1
50.	SEMg 56-4B	0,06	0,08	1390	0,73	44	0,85	0,412	2,1	1,1	2,2	0,00025	4	-	3,5
51.	SEMg 56-4C	0,09	0,12	1360	1,1	50	0,86	0,632	2	1,1	1,8	0,0003	5	-	4
52.	SEMg 63-4A	0,09	0,12	1350	0,95	50	0,85	0,632	1,9	1	1,8	0,00024	5	-	3,7
53.	SEMg 63-4B	0,12	0,17	1360	1,25	53	0,88	0,843	2,2	1	1,9	0,000307	6	-	4,3
54.	SEMg 63-4C	0,18	0,25	1350	1,72	58	0,78	1,273	2,3	0,8	1,6	0,00038	8	-	5,1
55.	SEMh 71-4B	0,25	0,33	1340	2,6	56	0,82	1,782	2	1	1,7	0,000852	10	-	6,3
56.	SEMh71-4C	0,37	0,5	1340	3	63	0,88	2,64	2,3	0,8	1,5	0,001099	14	-	6,3
57.	SEMh80-4B	0,55	0,75	1360	3,9	66	0,94	3,86	3,2	0,6	1,6	0,00208	20	-	10
58.	SEMh 80-4C	0,75	1	1340	5,6	65	0,9	5,35	2,5	0,65	1,5	0,002652	25	-	11,4
59.	SEMh 90-4S	0,75	1	1340	5,6	65	0,9	5,19	3	0,65	1,6	0,0024	25	-	12,3
60.	SEMh 90-4L	1,1	1,5	1300	7,8	67	0,92	8,08	2,2	0,5	1,4	0,0032	40	-	14,5
HIGH STARTING TORQUE MOTORS															
61.	SEg 63-4AF	0,12	0,17	1400	1,1	54	0,92	0,819	3,3	1,7	1,6	0,00024	6	14	3,8
62.	SEg 63-4BF	0,18	0,25	1380	1,45	57	0,95	1,246	3,2	1,5	1,5	0,000307	8	16	4,4
63.	SEg63-4CF	0,25	0,33	1400	1,8	68	0,92	1,705	3,3	1,6	1,4	0,00038	10	20	5,2
64.	SEMh71-4BF	0,25	0,33	1350	2,5	58	0,82	1,768	3	1,8	1,7	0,000852	8	12	6,3
65.	SEh 71-4BF	0,37	0,5	1360	3,1	62	0,87	2,6	3,5	1,8	1,3	0,000852	10	25	6,5
66.	SEMh71-4CF	0,37	0,5	1350	3,3	65	0,84	2,62	3,2	1,7	1,6	0,00101	12	16	7,8
67.	SEh 71-4CF	0,55	0,75	1360	4,1	65	0,9	3,86	3,6	1,9	1,4	0,00101	18	60	8
68.	SEMh80-4BF	0,55	0,75	1360	3,9	66	0,94	3,86	3	1,8	1,6	0,00208	20	25	10,8
69.	SEh 80-4BF	0,75	1	1370	4,9	70	0,95	5,23	3	1,8	1,4	0,00208	20	60	10,4
70.	SEMh80-4CF	0,75	1	1370	5,6	67	0,9	5,23	3,3	1,8	1,7	0,00265	25	30	12,8
71.	SEh 80-4CF	1,1	1,5	1400	7,4	74	0,91	7,5	3,6	1,9	1,5	0,00265	30	75	12,2
72.	SEh 90-4SF	1,1	1,5	1400	7,5	73	0,9	7,5	4	1,6	1,5	0,0024	30	75	13,7
73.	SEh 90-4LF	1,3	1,8	1360	9	72	0,91	9,13	3,2	1,8	1,4	0,0032	40	90	14,8

FOOT MOUNTED MOTORS - IM B3

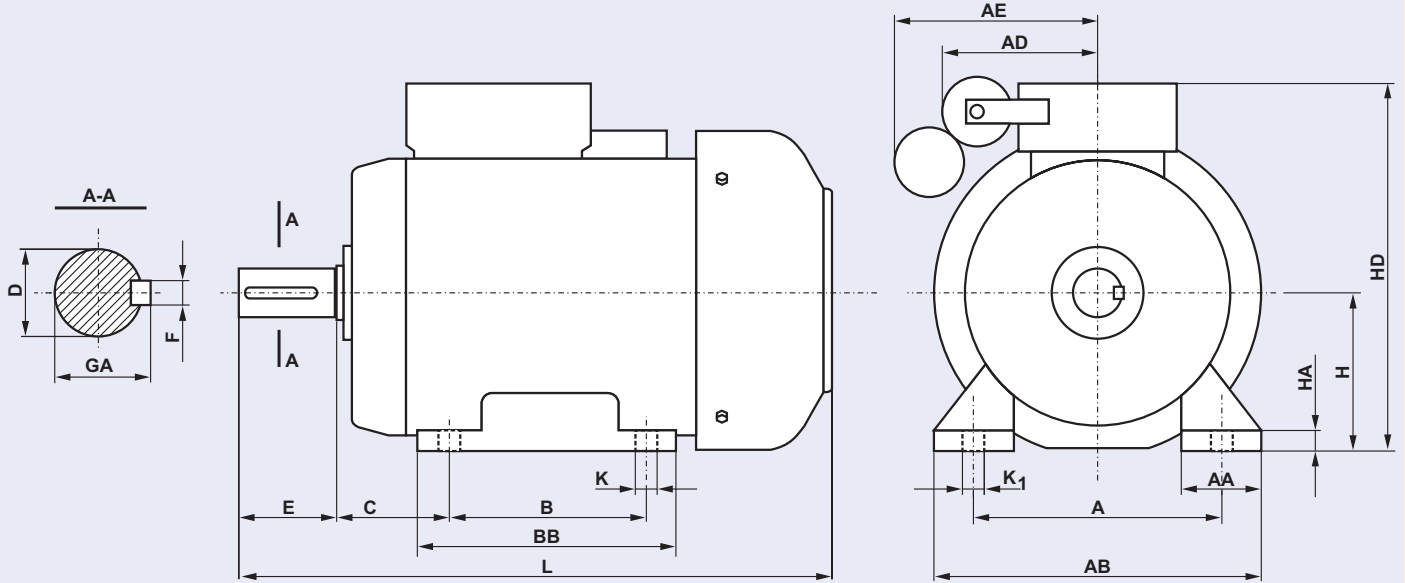

DIMENSION DRAWINGS

Motor Type	A	B	C	D	E	F	GA	H	K	K1	HA	AA	AB	BB	AE	AD	HD	L
SE(M)g56-A	90	71	36	9j6	20	3h9	10,2	56	5,8	8	7	30	110	92	-	74	154	188
SE(M)g56-B	90	71	36	9j6	20	3h9	10,2	56	5,8	8	7	30	110	92	-	74	154	196
SE(M)g56-C	90	71	36	9j6	20	3h9	10,2	56	5,8	8	7	30	110	92	-	74	154	204
SE(M)g63-A	100	80	40	11j6	23	4h9	12,5	63	7	10	8,5	36	124	106	-	74	165	202
SEg63-AF	100	80	40	11j6	23	4h9	12,5	63	7	10	8,5	36	124	106	100	74	165	245
SE(M)g63-B	100	80	40	11j6	23	4h9	12,5	63	7	10	8,5	36	124	106	-	74	165	214
SEg63-BF	100	80	40	11j6	23	4h9	12,5	63	7	10	8,5	36	124	106	100	74	165	257
SE(M)g63-C	100	80	40	11j6	23	4h9	12,5	63	7	10	8,5	36	124	106	-	74	165	228
SEg63-CF	100	80	40	11j6	23	4h9	12,5	63	7	10	8,5	36	124	106	100	74	165	271
SE(M)h71-B	112	90	45	14j6	30	5h9	16	71	7	10	8	45	142	116	-	90	182	245
SE(M)h71-BF	112	90	45	14j6	30	5h9	16	71	7	10	8	45	142	116	100	90	182	285
SE(M)h71-C	112	90	45	14j6	30	5h9	16	71	7	10	8	45	142	116	-	90	182	263
SE(M)h71-CF	112	90	45	14j6	30	5h9	16	71	7	10	8	45	142	116	100	90	182	303
SE(M)h80-B	125	100	50	19j6	40	6h9	21,5	80	10	13	9	55	160	130	-	95	200	278
SE(M)h80-BF	125	100	50	19j6	40	6h9	21,5	80	10	13	9	55	160	130	120	95	200	315
SE(M)h80-C	125	100	50	19j6	40	6h9	21,5	80	10	13	9	55	160	130	-	95	200	306
SE(M)h80-CF	125	100	50	19j6	40	6h9	21,5	80	10	13	9	55	160	130	120	95	200	343
SE(M)h90-S	140	100	56	24j6	50	8h9	27	90	10	13	12	60	170	153	-	95	208	316
SE(M)h90-SF	140	100	56	24j6	50	8h9	27	90	10	13	12	60	170	153	120	95	208	350
SE(M)h90-L	140	125	56	24j6	50	8h9	27	90	10	13	12	60	170	153	-	95	208	328
SE(M)h90-LF	140	125	56	24j6	50	8h9	27	90	10	13	12	60	170	153	120	95	208	364

FLANGE MOUNTED MOTORS - IM B5

DIMENSION DRAWINGS

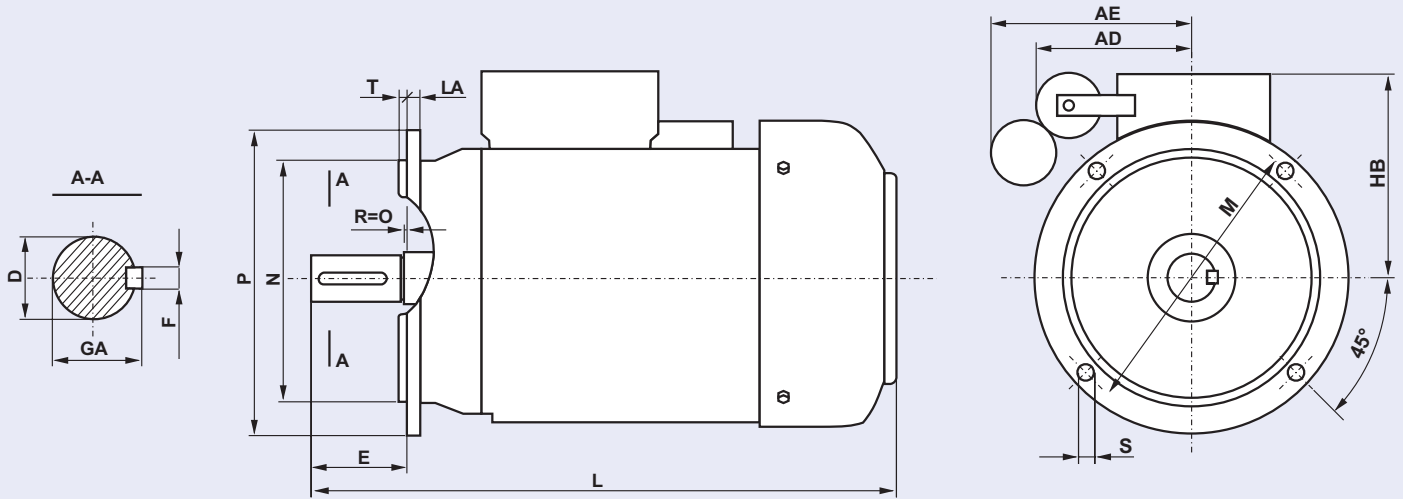

Motor Type	Flange	P	M	N	S	D	E	F	GA	LA	T	AE	AD	HB	L
SE(M)Kg56-A	B5	120	100	80j6	7	9j6	20	3h9	10,2	8	3	-	74	98	188
SE(M)Kg56-B	B5	120	100	80j6	7	9j6	20	3h9	10,2	8	3	-	74	98	196
SE(M)Kg56-C	B5	120	100	80j6	7	9j6	20	3h9	10,2	8	3	-	74	98	204
SE(M)Kg63-A	B5	140	115	95j6	10	11j6	23	4h9	12,5	9	3	-	74	102	202
SEKg63-AF	B5	140	115	95j6	10	11j6	23	4h9	12,5	9	3	100	74	102	245
SE(M)Kg63-B	B5	140	115	95j6	10	11j6	23	4h9	12,5	9	3	-	74	102	214
SEKg63-BF	B5	140	115	95j6	10	11j6	23	4h9	12,5	9	3	100	74	102	257
SE(M)Kg63-C	B5	140	115	95j6	10	11j6	23	4h9	12,5	9	3	-	74	102	228
SEKg63-CF	B5	140	115	95j6	10	11j6	23	4h9	12,5	9	3	100	74	102	271
SE(M)Kh71-B	B5	160	130	110j6	10	14j6	30	5h9	16	9	3,5	-	90	111	245
SE(M)Kh71-BF	B5	160	130	110j6	10	14j6	30	5h9	16	9	3,5	100	90	111	285
SE(M)Kh71-C	B5	160	130	110j6	10	14j6	30	5h9	16	9	3,5	-	90	111	263
SE(M)Kh71-CF	B5	160	130	110j6	10	14j6	30	5h9	16	9	3,5	100	90	111	303
SE(M)Kh80-B	B5	200	165	130j6	12	19j6	40	6h9	21,5	10	3,5	-	95	120	278
SE(M)Kh80-BF	B5	200	165	130j6	12	19j6	40	6h9	21,5	10	3,5	120	95	120	315
SE(M)Kh80-C	B5	200	165	130j6	12	19j6	40	6h9	21,5	10	3,5	-	95	120	306
SE(M)Kh80-CF	B5	200	165	130j6	12	19j6	40	6h9	21,5	10	3,5	120	95	120	343
SE(M)Kh90-S	B5	200	165	130j6	12	24j6	50	8h9	27	10	3,5	-	95	118	316
SE(M)Kh90-SF	B5	200	165	130j6	12	24j6	50	8h9	27	10	3,5	120	95	118	350
SE(M)Kh90-L	B5	200	165	130j6	12	24j6	50	8h9	27	10	3,5	-	95	118	328
SE(M)Kh90-LF	B5	200	165	130j6	12	24j6	50	8h9	27	10	3,5	120	95	118	364

FLANGE MOUNTED MOTORS - IM B14

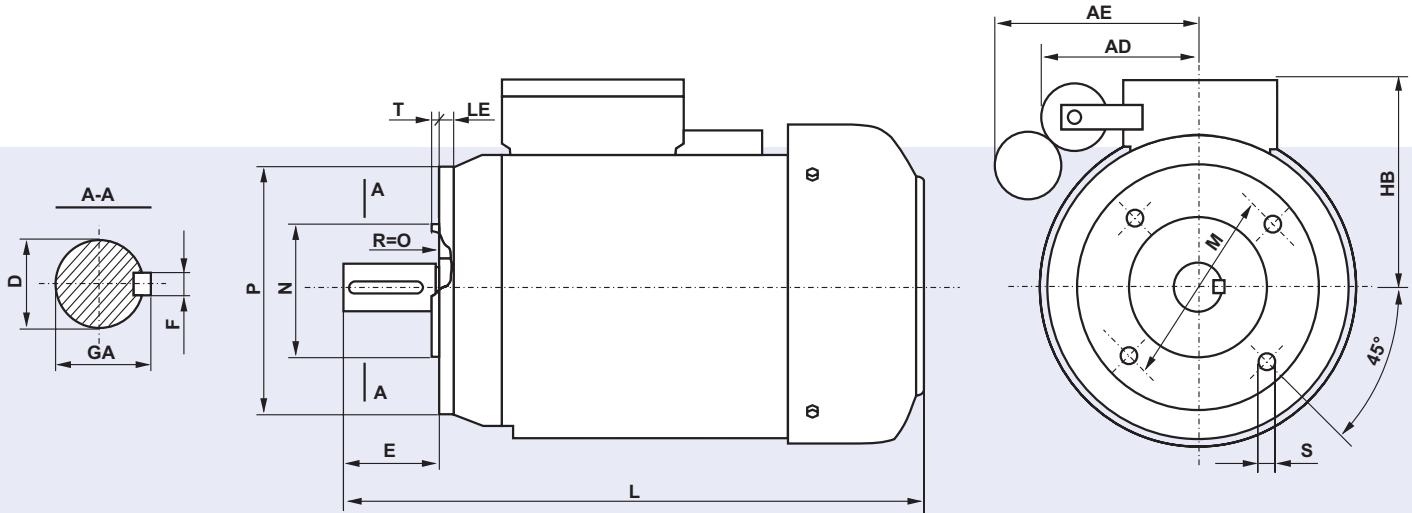

Motor Type	Flange	P	M	N	S	D	E	F	GA	LE	T	AE	AD	HB	L
SE(M)Kg56-A1	B14/C1	105	85	70j6	M6	9j6	20	3h9	10,2	15	2,5	-	74	98	188
SE(M)Kg56-A2	B14/C2	80	65	50j6	M5	9j6	20	3h9	10,2	12,5	2,5	-	74	98	188
SE(M)Kg56-B1	B14/C1	105	85	70j6	M6	9j6	20	3h9	10,2	15	2,5	-	74	98	196
SE(M)Kg56-B2	B14/C2	80	65	50j6	M5	9j6	20	3h9	10,2	12,5	2,5	-	74	98	196
SE(M)Kg56-C1	B14/C1	105	85	70j6	M6	9j6	20	3h9	10,2	15	2,5	-	74	98	204
SE(M)Kg56-C2	B14/C2	80	65	50j6	M5	9j6	20	3h9	10,2	12,5	2,5	-	74	98	204
SE(M)Kg63-A1	B14/C1	120	100	80j6	M6	11j6	23	4h9	12,5	14	3	-	74	102	202
SEKg63-AF1	B14/C1	120	100	80j6	M6	11j6	23	4h9	12,5	14	3	100	74	102	245
SE(M)Kg63-A2	B14/C2	90	75	60j6	M5	11j6	23	4h9	12,5	9,5	2,5	-	74	102	202
SEKg63-AF2	B14/C2	90	75	60j6	M5	11j6	23	4h9	12,5	9,5	2,5	100	74	102	245
SE(M)Kg63-B1	B14/C1	120	100	80j6	M6	11j6	23	4h9	12,5	14	3	-	74	102	214
SEKg63-BF1	B14/C1	120	100	80j6	M6	11j6	23	4h9	12,5	14	3	100	74	102	257
SE(M)Kg63-B2	B14/C2	90	75	60j6	M5	11j6	23	4h9	12,5	9,5	2,5	-	74	102	214
SEKg63-BF2	B14/C2	90	75	60j6	M5	11j6	23	4h9	12,5	9,5	2,5	100	74	102	257
SE(M)Kg63-C1	B14/C1	120	100	80j6	M6	11j6	23	4h9	12,5	14	3	-	74	102	228
SEKg63-CF1	B14/C1	120	100	80j6	M6	11j6	23	4h9	12,5	14	3	100	74	102	271
SE(M)Kg63-C2	B14/C2	90	75	60j6	M5	11j6	23	4h9	12,5	9,5	2,5	-	74	102	228
SEKg63-CF2	B14/C2	90	75	60j6	M5	11j6	23	4h9	12,5	9,5	2,5	100	74	102	271
SE(M)Kh71-B1	B14/C1	140	115	95j6	M8	14j6	30	5h9	16	14	3	-	90	111	245
SE(M)Kh71-BF1	B14/C1	140	115	95j6	M8	14j6	30	5h9	16	14	3	100	90	111	285
SE(M)Kh71-B2	B14/C2	105	85	70j6	M6	14j6	30	5h9	16	12	2,5	-	90	111	245
SE(M)Kh71-BF2	B14/C2	105	85	70j6	M6	14j6	30	5h9	16	12	2,5	100	90	111	285
SE(M)Kh71-C1	B14/C1	140	115	95j6	M8	14j6	30	5h9	16	14	3	-	90	111	263
SE(M)Kh71-CF1	B14/C1	140	115	95j6	M8	14j6	30	5h9	16	14	3	100	90	111	303
SE(M)Kh71-C2	B14/C2	105	85	70j6	M6	14j6	30	5h9	16	12	2,5	-	90	111	263
SE(M)Kh71-CF2	B14/C2	105	85	70j6	M6	14j6	30	5h9	16	12	2,5	100	90	111	303
SE(M)Kh80-B1	B14/C1	160	130	110j6	M8	19j6	40	6h9	21,5	14	3,5	-	95	120	278
SE(M)Kh80-BF1	B14/C1	160	130	110j6	M8	19j6	40	6h9	21,5	14	3,5	120	95	120	315
SE(M)Kh80-B2	B14/C2	120	100	80j6	M6	19j6	40	6h9	21,5	12	3	-	95	120	278
SE(M)Kh80-BF2	B14/C2	120	100	80j6	M6	19j6	40	6h9	21,5	12	3	120	95	120	315
SE(M)Kh80-C1	B14/C1	160	130	110j6	M8	19j6	40	6h9	21,5	14	3,5	-	95	120	306
SE(M)Kh80-CF1	B14/C1	160	130	110j6	M8	19j6	40	6h9	21,5	14	3,5	120	95	120	343
SE(M)Kh80-C2	B14/C2	120	100	80j6	M6	19j6	40	6h9	21,5	12	3	-	59	120	306
SE(M)Kh80-CF2	B14/C2	120	100	80j6	M6	19j6	40	6h9	21,5	12	3	120	95	120	343
SE(M)Kh90-S1	B14/C1	160	130	110j6	M8	24j6	50	8h9	27	10	3,5	-	95	118	316
SE(M)Kh90-SF1	B14/C1	160	130	110j6	M8	24j6	50	8h9	27	10	3,5	120	95	118	350
SE(M)Kh90-S2	B14/C2	140	115	95j6	M8	24j6	50	8h9	27	10	3	-	95	118	316
SE(M)Kh90-SF2	B14/C2	140	115	95j6	M8	24j6	50	8h9	27	10	3	120	95	118	350
SE(M)Kh90-L1	B14/C1	160	130	110j6	M8	24j6	50	8h9	27	10	3,5	-	95	118	328
SE(M)Kh90-LF1	B14/C1	160	130	110j6	M8	24j6	50	8h9	27	10	3,5	120	95	118	364
SE(M)Kh90-L2	B14/C2	140	115	95j6	M8	24j6	50	8h9	27	10	3	-	95	118	328
SE(M)Kh90-LF2	B14/C2	140	115	95j6	M8	24j6	50	8h9	27	10	3	120	95	118	364

DIMENSION DRAWINGS