

**CANTONI**  
**MOTOR**

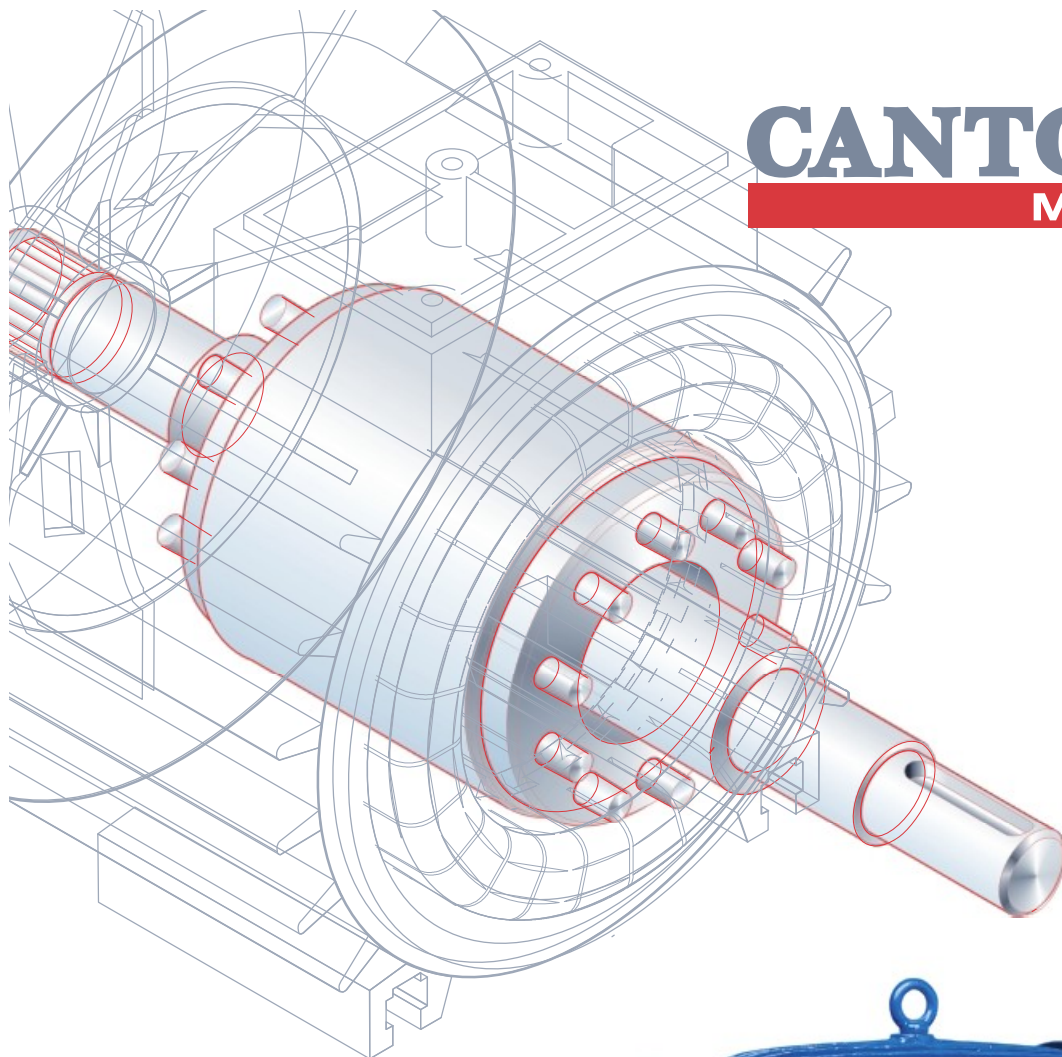

**General  
Purpose  
3-Phase  
Induction  
Motors**

EFF 1  
EFF 2



Certificates

Cantoni Motor SA  
ISO 9001  
KEMA  
Since September 30, 1999  
Number 99515

Besel SA  
ISO 9001  
DQS  
Since July 21, 1995  
Number 002887Q1

Indukta SA  
ISO 9001  
KEMA  
Since April 1, 1993  
ISO 14001  
KEMA  
Since July 1, 2001  
Number 2019916

Celma SA  
ISO 9001  
Germanischer Lloyd  
since June 16, 1995  
Number QS-243 HH  
ISO 14001  
Germanischer Lloyd  
Since November 15, 1999  
Number EM-1835 HH

Emit SA  
ISO 9001  
Polski Rejestr Statków  
Since January 23, 1997  
Number NC-034/00

**KEMA**

# CERTIFICATE

Number: 99515

The management system of:

**CANTONI Motor S.A.**  
Warszawa, Poland

including the implementation meets the requirements of the standard:

## ISO 9001:2000

Scope:  
Export sale of electric motors, co-ordination of the procurement of materials for the production of electric motors, accounting reporting for the companies of the Group.

The file that forms the basis of this certificate:  
99515-01A

This certificate is valid until: April 1, 2006

Issued for the first time: September 30, 1999

Ing. M.J. van der Dussen  
managing director

MEMBER OF THE INTERNATIONAL NETWORK FOR MANAGEMENT SYSTEM ASSESSMENT AND CERTIFICATION "IQNET".

KEMA Quality B.V.  
Lindendreef 310, Arnhem  
P.O. Box 5185, 6802 ED Arnhem, The Netherlands  
Telephone +31 26 356 20 00, Telefax +31 26 352 58 00

ACCREDITED BY  
THE DUTCH COUNCIL  
FOR ACCREDITATION

**CERTYFIKAT  
CERTIFICATE**

Przyznany organizacji:  
Issued for:

**Zakład Maszyn Elektrycznych "EMIT" S.A.**  
ul. Narutowicza 72  
99-320 Żychlin

Biuro Certyfikacji Polskiego Rejestru Statków S.A. zawiadacza, że System Zarządzania Jakością wyżej wymienionej organizacji został oceniony i stwierdzono zgodność z wymaganiami.

Certification Bureau of Polish Register Statków S.A. certifies that the Quality Management System of the above organization has been assessed and found to be in accordance with the requirements of:

**ISO 9001:2000**

Zakres certyfikacji:  
PROJEKTOWANIE I PRODUKCJA:  
- SILNIKÓW ELEKTRYCZNYCH TRÓJFAZOWYCH  
- SILENIKÓW ELEKTRYCZNYCH  
- MASZYN PRĄDZĄCZYCH  
- CZĘŚCI PODCZEPKOWYCH DO MASZYN ELEKTRYCZNYCH  
- WZMOCNIENIA SPRĘŻYNI  
ORAZ REMONTY MASZYN ELEKTRYCZNYCH

Scope of certification:  
DESIGN AND MANUFACTURE OF:  
- THREE-PHASE INDUCTION MOTORS  
- SYNCHRONOUS GENERATORS  
- POWER GENERATING SETS  
- PARTS AND SUBASSEMBLIES FOR ELECTRIC MACHINES  
- WELDED STRUCTURES  
AND REPAIRS OF ELECTRIC MACHINES

Pierwsze wydanie Certyfikatu:  
Certificate first issue: **23.01.1997**

Certyfikat jest ważny do:  
The Certificate is valid until: **22.01.2006**

Nr Certyfikatu:  
Certificate No.: **NC-034**

Gdańsk, 26.01.2006

AC 014  
QMS

Jan Jaskowski  
Bogdan Przytycki

# CERTIFICATE

Number: 2019916

The management system of:

**Fabryka Maszyn Elektrycznych  
INDUKTA SA**  
Bielsko-Biała, Poland

including the implementation meets the requirements of the standard:

## ISO 9001:2000 ISO 14001

packing and dispatch of electrical  
an output up to and including 30KW.

22.05.1995

# CERTIFICATE

**DQS GmbH**  
Deutsche Gesellschaft zur Zertifizierung von Managementsystemen

herby certifies that the company

**Fabryka Silników Elektrycznych  
"BESEL" S.A.**  
ul. Elektryczna 8  
49-200 Brog  
Poland

for the scope:  
design, production sale and service of single-phase  
and three-phase asynchronous, electric motors of low power

has implemented and maintains a

**Quality Management System.**

An audit, documented in a report, has verified that this  
quality management system fulfills the requirements  
of the following standard:

**DIN EN ISO 9001 : 2000**  
December 2000 edition

This certificate is valid until: **2006-07-30**

Certificate Registration No.: **002887 QM**

Frankfurt am Main, Berlin **2003-07-31**

Dr.-Ing. K. Pöschel  
MANAGING DIRECTORS  
Dipl.-Ing. S. Herlich

Certification Body: DQS GmbH Deutsche Gesellschaft zur Zertifizierung von Managementsystemen  
August-Schnee-Straße 10, 60529 Frankfurt am Main - Germany  
Office: DQS Polska Sp. z o.o.  
ul. Narutowicza 21, 83-674 Włocławek - Polska

Germanischer Lloyd Certification GmbH

# CERTIFICATE

The Germanischer Lloyd Certification GmbH, 20459 Hamburg,  
herewith certifies that the company

**Maszyny Elektryczne CELMA S.A.**  
ul. 3 Maja 19, PL-43-400 Cieszyń

with the subsidiary

**Odlewnia Żeliwa Cieszyń Sp. z o.o.**  
ul. 3 Maja 19, PL-43-400 Cieszyń

has established and maintains a Quality Management System relevant for:  
**Design, production and repair of electric machines  
Iron castings**

Germanischer Lloyd Certification GmbH has audited the company. Evidence was provided  
that the Quality Management System fulfills the requirements of the following standard:

**DIN EN ISO 9001:2000**

The validity of this certificate is subject to the company applying and maintaining its Quality  
Management System in accordance with the standard indicated. This will be monitored by  
Germanischer Lloyd Certification GmbH.

Initial certification: May 22, 1995  
The certificate is valid until December 06, 2006  
Hamburg, December 06, 2003

Certificate No. **QS-243 HH**

TGA-ZM-07-01-00  
Dr. Weber  
P. Schröder

# CERTIFICATE

Przyznany organizacji:  
Issued for:

**Maszyny Elektryczne CELMA S.A.**  
ul. 3 Maja 19  
43-400 Cieszyń

Biuro Certyfikacji Polskiego Rejestru Statków S.A. zawiadacza, że System Zarządzania Jakością wyżej wymienionej organizacji został oceniony i stwierdzono zgodność z wymaganiami.

Certification Bureau of Polish Register Statków S.A. certifies that the Quality Management System of the above organization has been assessed and found to be in accordance with the requirements of:

**ISO 9001:2000**

Zakres certyfikacji:  
PROJEKTOWANIE, PRODUKCJA I REMONTY MASZYN ELEKTRYCZNYCH

Scope of certification:  
DESIGNING, MANUFACTURING AND REPAIRING OF ELECTRIC MACHINES

Pierwsze wydanie Certyfikatu:  
Certificate first issue: **22.05.1995**

Certyfikat jest ważny do:  
The Certificate is valid until: **27.10.2006**

Nr Certyfikatu:  
Certificate No.: **NC-005**

Gdańsk, 26.10.2003

Jan Jaskowski  
Bogdan Przytycki

# Cantoni<sup>®</sup>

## GROUP

**Cantoni Motor S.A.**  
Pańska 81/83, 00-834 Warszawa, Poland  
tel.: +48 22 652 84 05  
fax: +48 22 652 84 00  
e-mail: [motor@cantonimotor.com.pl](mailto:motor@cantonimotor.com.pl)  
<http://www.cantonimotor.com>

*since 1950*



*since 1878*



*since 1954*



*since 1920*



*since 1921*



Contents

**General information**

**pages 5-12**

*Description of the catalogue version*

*Description of the customised version*

*Ratings-tolerances*

*Standards and equivalents*

*Efficiency*

*Insulation classification*

*Degree of protection*

*Mounting arrangements*

*Motor feet*

*Terminal box*

*Vibration and acoustic level*

*Housing, endshields*

*Permissible loading on the shaft end*

*Bearings*

*Cooling system*

*Ordering information*

**Data tables**

**pages 13-17**

**Dimension drawings**

**pages 18-28**

**List of motor parts**

**pages 29-31**

**Production program**

**pages 34-35**

## DESCRIPTION OF THE CATALOGUE VERSION

Duty:	S1
Rated voltage:	380V, 400V, 690V ( $\Delta/Y$ )
Frequency:	50 Hz
Ambient temperature:	from -15°C to + 40°C
Mounting height:	up to 1000 m above sea level
Number of free shaft ends:	1
Insulation class:	F
Bearings:	according to page 12

Other specifications dependent on the frame size:

Frame size	Degree of protection	Position of the terminal box	Number of terminals	Number of cable outlets	Optional rotation of the terminal box	Glands	Temperature sensors in winding	Bearing lubrication system	Thermal protection of bearings
Sg 56	IP 55	top	6	1	180°	M 20	on request	no	no
Sg 63	IP 55	top	6	1	180°	M 20	on request	no	no
Sh 71	IP 55	top	6	1	180°	M 20	on request	no	no
Sh 80	IP 55	top	6	1	180°	M 20	on request	no	no
Sh 90	IP 55	top	6	2	180°	M 20	on request	no	no
Sg 100	IP 55	top	6	2	180°	M 20	on request	no	no
Sg 112	IP 55	top	6	2	180°	M 25	on request	no	no
Sg 132	IP 55	top	6	2	180°	M 25	on request	no	no
Sg 160	IP 55	top	6	2	180°	M 40	on request	on request	on request
Sg 180	IP 55	top	6	2	180°	M 40	on request	on request	on request
Sg 200	IP 55	right	6	2	4 × 90°	M 50	PTC	yes	on request
Sg 225	IP 55	right	6	2	4 × 90°	M 50	PTC	yes	on request
Sg 250	IP 55	right	6	2	4 × 90°	M 63	PTC	yes	on request
Sg 280	IP 55	right	6	2	4 × 90°	M 63	PTC	yes	on request
Sg 315	IP 55	right	6	2	4 × 90°	M 76	PTC	yes	on request
SEE 315	IP 55	top	6	2	4 × 90°	M 76	PTC	yes	on request
Sg 355	IP 55	right	6	2	4 × 90°	M 76	PTC Mark A	yes	on request
SEE 355	IP 55	top	6	2	4 × 90°	M 76	PTC Mark A	yes	on request
Sh 355	IP 55	top	6	2	4 × 90°	M 76	Pt 100	yes	Pt 100
Sh 400	IP 55	top	3 (bars)	3	180°	3× $\phi$ 55	Pt 100	yes	Pt 100
Sh 450	IP 55	top	3 (bars)	3	180°	3× $\phi$ 55	Pt 100	yes	Pt 100
Sh 500	IP 55	top	3 (bars)	3	180°	3× $\phi$ 55	Pt 100	yes	Pt 100

*We are able to supply almost any motor made according to customer's specifications*

## DESCRIPTION OF THE CUSTOMISED VERSION

Different supply voltage	
Frequency:	60 Hz
Degree of protection:	IP 56
Insulation class:	H
Number of free shaft ends:	2
Tropicalization	
Different bearings	
Different duty type	
Adaptation for supply from a frequency inverter	
Different versions per customer's specifications	

*As part of our development program, we reserve the right to alter or amend any of the specifications without giving prior notice*

## RATINGS - TOLERANCES

Permissible deviations of real values from catalogue values according to IEC 60034-1:

Power factor $\cos \varphi$	$\Delta \cos \varphi = -1/6 (1 - \cos \varphi_N)$
Efficiency $\eta$	$\Delta \eta = -15\% (100 - \eta_N)$ for $P_N \leq 50 \text{ kW}$ $\Delta \eta = -10\% (100 - \eta_N)$ for $P_N > 50 \text{ kW}$
Speed $n$	$\Delta n = \pm 20\% (n_s - n_N)$ for $P_N > 1 \text{ kW}$ $\Delta n = \pm 30\% (n_s - n_N)$ for $P_N \leq 1 \text{ kW}$
Locked rotor current $I_r/I_N$	$\Delta(I_r/I_N) = +20\% (I_r/I_N)$
Locked rotor torque $M_r/M_N$	$\min (M_r/M_N) = -15\% (M_r/M_N)$ $\max (M_r/M_N) = +25\% (M_r/M_N)$
Breakdown torque $M_{\max}/M_N$	$\Delta(M_{\max}/M_N) = -10\% (M_{\max}/M_N)$
Moment of inertia $J [\text{kgm}^2]$	$\Delta J = \pm 10\% J$
Sound pressure level $L_{pA} [\text{dB}]$	$\Delta L_{pA} = +3 \text{ dB /A/}$

The efficiency of motors of frame size 56 - 180 is determined by method of total loss measurement, and the efficiency of motors of frame size 200 - 500 is determined by method of summary of losses.

The rated current of a motor is the value consumed by a given motor at the rated load, rated supply voltage, rated efficiency and power factor.

Real current consumed by the motor at the rated supply voltage and rated load results from the real efficiency and real power factor (permissible deviations).

No-load current in small motors and low speeds, e.g. frame size 90,  $2p=6$  or  $2p=8$ , may be approximately slightly lower or equal to the rated current. In case of supply voltage higher than the rated one it may even exceed the rated current.

## STANDARDS AND EQUIVALENTS

The electric motors are manufactured according to international standards:

		Country	Standard
Rating and performance	IEC 60034-1	Germany	DIN VDE 0530; DIN EN 60034/VDE; DIN IEC 34; DIN 42673;                      DIN 42677
Methods for determining losses and efficiency	IEC 60034-2		
Classification of degrees of protection	IEC 60034-5		
Methods of cooling	IEC 60034-6	Great Britain	BS 5000;                      BS 4999
Symbols of construction and mounting arrangements	IEC 60034-7		
Terminal markings and direction of rotation	IEC 60034-8	France	NFC 51 111 51 120; NFC 51 200;                      NFC 51 115 NFC 51 117;                      NFC 51 119
Noise limits	IEC 60034-9		
Dimensions and output for electric machines	IEC 60072-1		
Vibration limits	IEC 60034-14	Italy	CEI 2-3 1988; CEI 2-6;                              CEI 2-7 CEI 2-8;                              CEI 2-15 CEI/UNEL 13113-71; CEI/UNEL 13117-71; CEI/UNEL 13118-71;
The products comply with the specifications regarding the electromagnetic compatibility specified in: EN 61000-6-1, EN 61000-6-2, EN 61000-6-3, EN 61000-6-4.			

All the motors are manufactured in Quality Assurance System consistent with ISO 9001.

ISO9001

The motors covered by the present catalogue comply with the regulations and standards effective in other countries, consistent with IEC standards.

IEC

All the motors described in the present catalogue are provided with CE mark. It means that our products are consistent with the European Union directives regarding the safety measures.

CE



**EFFICIENCY OF MOTORS**

Since 2001 Cantoni Motor has started offering high efficiency series SEE motors. The SEE motors belong to the EFF1 efficiency class (high efficiency) in accordance with the recommendations of the European Association of Electric Motor Manufacturers CEMEP acting under the auspices of the European Power Committee.

The present catalogue mostly describes the electric motors belonging to the second efficiency class EFF2 (improved efficiency).

These motors show high efficiency, exceeding average efficiency of motors manufactured by other European manufacturers.

Output [kW]	Average efficiency of SEE high efficiency motors from Cantoni Motor [%]	Average efficiency of Sg and Sh motors from Cantoni Motor [%]	Average efficiency of motors from other manufacturers [%]
0,75	83,9	75,0	73,7
1,1	83,8	76,7	75,9
1,5	85,0	79,0	78,0
2,2	86,4	82,0	80,1
3,0	87,4	82,7	81,5
4,0	88,3	85,1	83,7
5,5	89,2	85,9	85,0
7,5	90,1	87,0	86,4
11	91,0	89,0	87,0
15	91,8	89,5	88,9
18,5	92,2	90,5	90,1
22	92,6	91,0	89,2
30	93,5	92,5	91,0
37	94,3	92,6	92,1
45	94,5	94,0	92,4
55	95,0	93,5	92,7
75	95,2	94,2	92,1
90	95,2	94,8	93,2
110	95,5	94,2	93,0
132	95,6	94,9	94,0
160	95,9	95,6	94,7
250	96,3	96,3	95,0
315	96,6	96,6	95,6

(2p=4)

Average efficiency of SEE high efficiency motors from Cantoni Motor

Average efficiency of Sg and Sh motors from Cantoni Motor

Average efficiency of motors from other manufacturers

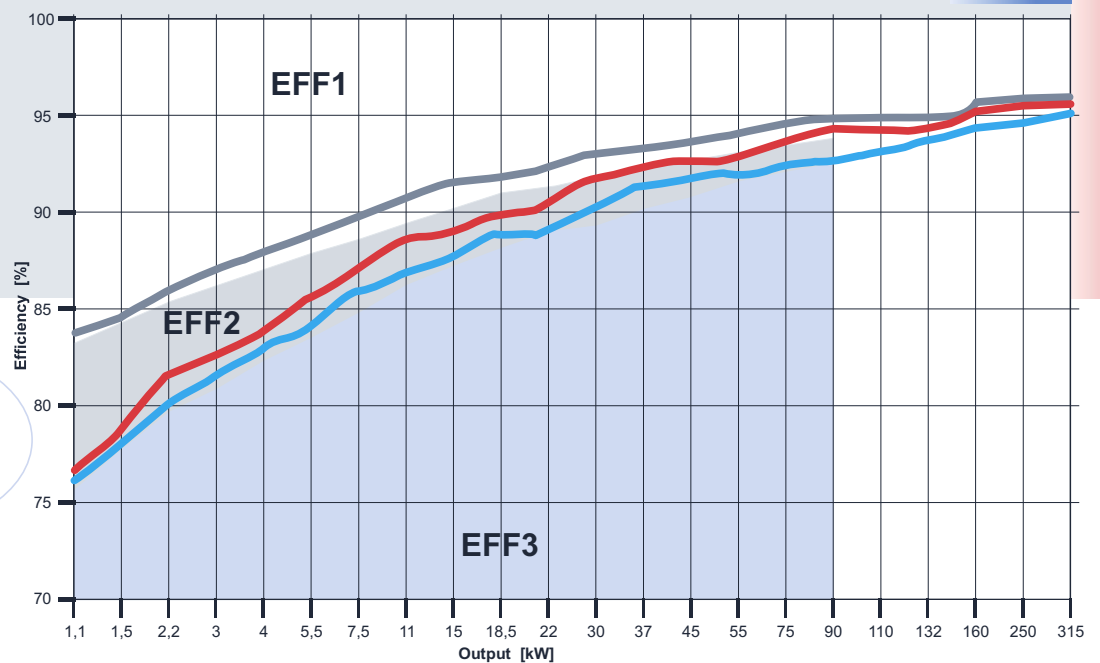

EFF 1

EFF 2

## INSULATION CLASSIFICATION

The insulation system of an electric motor is determined by a given insulation class on the basis of its thermal resistance. This thermal resistance should be guaranteed by the entire set of electric insulating materials used in the motor insulating system.

Thermal resistance classification is related to the temperature of the hotspot in the insulation occurring during rated operating conditions of the electric motor, allowing for the highest permissible rise in average temperature.

This rise should be selected so that at the highest permissible ambient temperature, the temperature of the hotspot in insulation will not exceed the value assigned to a given thermal resistance class.

Symbols of thermal resistance classes (permissible insulation temperatures for ambient temperature of 40°C)

Symbol	Temperature [°C]
A	105
E	120
B	130
F	155
H	180

Insulation class F for an electric motor means that at ambient temperature of 40°C the temperature rise of its windings may be max. 105°C with the additional temperature margin of 10°C (under specified measuring conditions in accordance with the IEC 60034-1 standard).

## Class F

The motors made by Cantoni Motor in their basic version have the insulation class F while the temperature rise is for class B. It means longer life of motors.

On customer's demand, we make motors with insulation class H.

Strengthened insulation system makes it possible to supply our motors from frequency inverters.

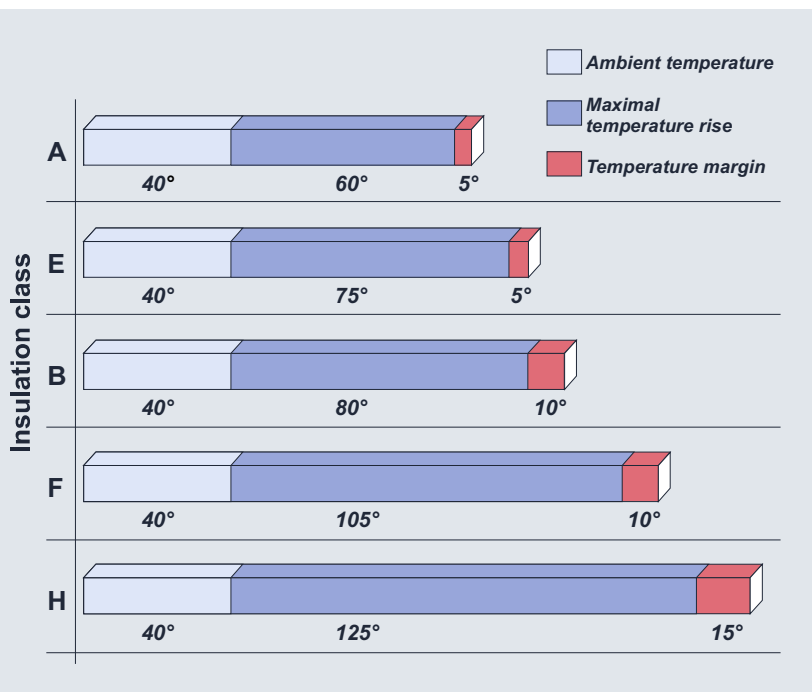

## DEGREE OF PROTECTION IP

According to the IEC 60034-5 standard the electric motors are provided with IP code which determines the degree of protection ensured by the housing against access to dangerous parts, introducing foreign matter and/or water.

The IP code consists of IP code letters and two obligatory digits, meaning:

The first digit (protection from introduction Of solid foreign matter)		The second digit (protection against penetration of water and its harmful effects)	
IP	Definition	IP	Definition
0	no protection	0	no protection
1	diameter $\geq$ 50 mm	1	dropping vertically
2	diameter $\geq$ 12,5 mm	2	dropping (up to 15°)
3	diameter $\geq$ 2,5 mm	3	sprayed
4	diameter $\geq$ 1,0 mm	4	splashed
5	limited protection against dust	5	in stream
		6	in strong stream
		7	under short-time immersion
		8	under permanent immersion



The motors described in the present catalogue in their basic version have the IP 55 degree of protection.

On demand we make motors with the IP 56 degree of protection.

# IP55

## MOUNTING ARRANGEMENTS

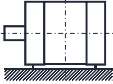
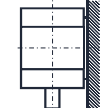
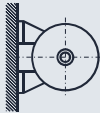
According to the IEC 60034-7 standard

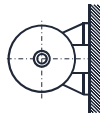
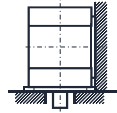
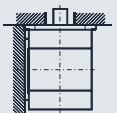
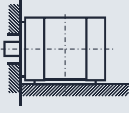
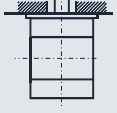
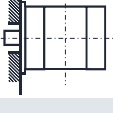
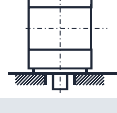
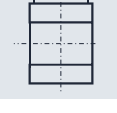
	Horizontal shaft			Vertical shaft			
	Designation			Designation			
	Code II	Code I	Frame size		Code II	Code I	Frame size
	IM 1001	IM B3	56 ÷ 500		IM 1011	IM V5	56 ÷ 315 except Sg 315 M6C except Sg 315 M8C
	IM 1051	IM B6	56 ÷ 280		IM 1031	IM V6	56 ÷ 315 except Sg 315 M6C except Sg 315 M8C
	IM 1061	IM B7	56 ÷ 280		IM 2011 or IM 2111	IM V15	56 ÷ 315 except SLg 315 M6C except SLg 315 M8C
	IM 1071	IM B8	56 ÷ 280		IM 2031 or IM 2131	IM V36	56 ÷ 315 except SLg 315 M6C except SLg 315 M8C
	IM 2001	IM B35	56 ÷ 500		IM 3011	IM V1	56 ÷ 500 except SVEE 355 (2-pole) except SVh 355 (2-pole) except SVh 400 (2-pole)
	IM 2101	IM B34	56 ÷ 132		IM 3031	IM V3	56 ÷ 280
	IM 3001	IM B5	56 ÷ 315 except SKg 315 M6C except SKg 315 M8C		IM 3611	IM V18	56 ÷ 180
	IM 3601	IM B14	56 ÷ 132		IM 3631	IM V19	56 ÷ 180

MOUNTING ARRANGEMENTS

### MOTOR FEET

Motors of frame size  $\leq 112$  have screwed feet.  
Motors of frame size 132 have screwed feet or integrated with the motor housing.  
Motors of frame size  $\geq 160$  have feet integrated with the motor housing.

### TERMINAL BOX

Terminal boxes of low voltage motors have threaded inlet holes designed for mounting cable glands. The box contains terminal board with marked terminals making possible connection of supply cables.

In addition, terminal boxes may be provided with additional terminals connected to the ends of thermal protection or anticondensation heater circuits and extra glands to connect these circuits.

Low voltage high-power motors contain terminal boxes with cable gland seals and cable clamps to prevent their removal. Inside the boxes there are special clamps used to ground the supply cable armouring.

In low voltage motors of very high power three supply busbar are used.

Box covers of low voltage high-power motors are made in form of antiimplosion membranes.

The circuits of thermal protection and anticondensation heaters are connected to separate terminal boxes.

### VIBRATION LEVEL AND ACOUSTIC POWER

VN

The rotor balancing method guarantees maintaining a normal vibration level VN in accordance with the IEC 60034-14 standard and basic acoustic power level in accordance with the IEC 60034-9 standard. On customer's demand the motors may be made with reduced vibration or noise level.

**HOUSING, END SHIELDS, FEET**

Frame size [mm]	Motor housing	End shields	Feet
56	Aluminium	Aluminium	Aluminium - screwed
63	Aluminium	Aluminium	Aluminium - screwed
71	Aluminium	Aluminium	Aluminium - screwed
80	Aluminium	Aluminium	Aluminium - screwed
90	Aluminium	Aluminium	Aluminium - screwed
100	Aluminium	Aluminium	Aluminium - screwed
112	Aluminium	Cast iron	Aluminium - screwed
132	Cast iron	Cast iron	Cast iron - screwed
160	Cast iron	Cast iron	Cast iron - integrated
180	Cast iron	Cast iron	Cast iron - integrated
200	Cast iron	Cast iron	Cast iron - integrated
225	Cast iron	Cast iron	Cast iron - integrated
250	Cast iron	Cast iron	Cast iron - integrated
280	Cast iron	Cast iron	Cast iron - integrated
315	Cast iron	Cast iron	Cast iron - integrated
355	Cast iron	Cast iron	Cast iron - integrated
400	Cast iron	Cast iron	Cast iron - integrated
450	Cast iron	Cast iron	Cast iron - integrated
500	Cast iron	Cast iron	Cast iron - integrated

In motors of frame size 80, 90 and 100: on request end shields may be made of cast iron.

In motors of frame size 132: feet may be integrated with housing.

**Motor housing**

 aluminium  cast iron

**aluminium**

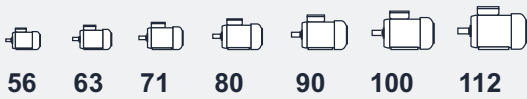

**cast iron**

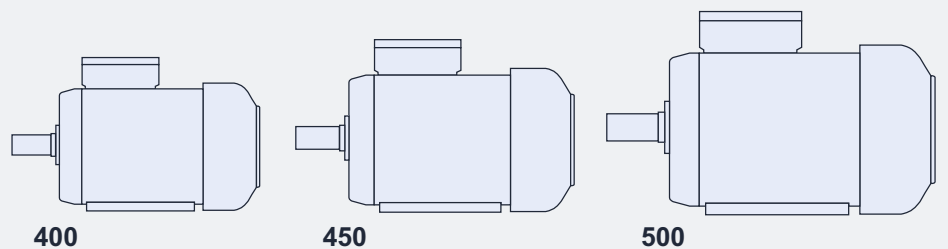
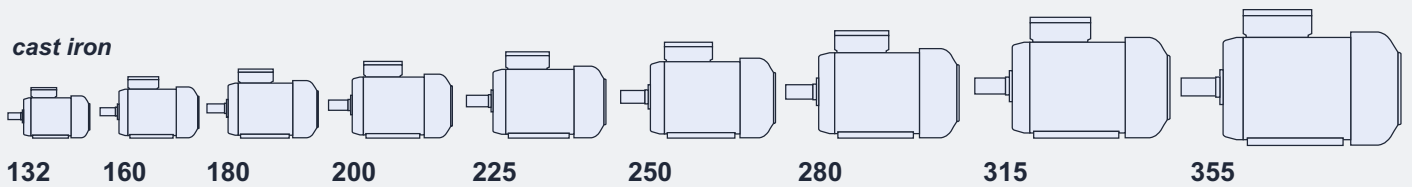

PERMISSIBLE LOADING ON THE SHAFT END

Frame size	Number of poles	Horizontal operation		Vertical operation			Frame size	Number of poles	Horizontal operation		Vertical operation		
		$F_R(x=0)$	$F_R(x=\max)$	$F_p$	$F_{a1}$	$F_{a2}$			$F_R(x=0)$	$F_R(x=\max)$	$F_p$	$F_{a1}$	$F_{a2}$
		[kN]		[kN]					[kN]		[kN]		
Sg 56	2	0,20	0,16	0,04	0,03	0,05	Sg 200 LB	6	2,70	2,20	2,40	1,60	3,40
Sg 56	4	0,25	0,20	0,05	0,04	0,06	Sg 200 L	8	3,10	2,60	2,7	2,00	3,60
Sg 63	2	0,20	0,16	0,04	0,04	0,06	Sg 225 S	4	2,90	2,30	2,50	1,80	3,40
Sg 63	4	0,25	0,20	0,06	0,05	0,07	Sg 225 S	8	3,90	3,10	3,20	2,50	4,20
Sg 63	6	0,27	0,22	0,06	0,05	0,07	Sg 225 M	2	2,20	1,80	1,70	1,10	2,50
Sh 71	2	0,29	0,24	0,07	0,05	0,09	Sg 225 M	4	2,70	2,10	2,40	1,60	3,50
Sh 71	4	0,36	0,30	0,09	0,07	0,11	Sg 225 M	6	3,10	2,50	2,80	1,90	4,00
Sh 71	6	0,40	0,35	0,10	0,08	0,12	Sg 225 M	8	3,70	2,90	3,10	2,30	4,30
Sh 71	8	0,40	0,35	0,11	0,09	0,13	Sg 250 M	2	2,60	2,10	2,00	1,30	3,00
Sh 80	2	0,33	0,27	0,09	0,06	0,12	Sg 250 M	4	3,20	2,60	2,80	1,80	4,20
Sh 80	4	0,44	0,37	0,12	0,09	0,15	Sg 250 M	6	3,60	2,90	3,20	2,00	4,90
Sh 80	6	0,51	0,42	0,14	0,11	0,17	Sg 250 M	8	4,10	3,40	3,60	2,30	5,30
Sh 80	8	0,51	0,42	0,17	0,15	0,20	Sg 280 S	2	3,20	2,70	2,60	1,40	4,00
Sh 90	2	0,58	0,44	0,53	0,30	0,40	Sg 280 S	4	3,90	3,30	3,50	2,10	5,40
Sh 90	4	0,64	0,52	0,60	0,30	0,40	Sg 280 S	6	5,00	4,20	4,20	2,90	5,90
Sh 90	6	0,74	0,68	0,73	0,30	0,40	Sg 280 S	8	5,50	4,60	4,60	3,30	6,50
Sh 90	8	0,82	0,74	0,80	0,30	0,40	Sg 280 M	2	3,10	2,50	2,50	1,30	4,10
Sg 100	2	0,78	0,56	0,70	0,25	0,40	Sg 280 M	4	3,70	3,10	3,50	1,90	5,50
Sg 100	4	0,81	0,79	0,83	0,25	0,40	Sg 280 M	6	4,80	4,00	4,10	2,70	6,10
Sg 100	6	0,98	0,92	0,98	0,25	0,40	Sg 280 M	8	5,20	4,30	4,50	2,90	6,70
Sg 100	8	1,12	1,04	1,11	0,25	0,40	Sg 315 S	2	3,70	3,20	3,00	1,60	4,80
Sg 112	2	0,70	0,56	0,67	0,25	0,40	Sg 315 S	4	6,40	5,30	4,90	3,10	7,30
Sg 112	4	0,81	0,71	0,79	0,25	0,40	Sg 315 S	6	7,40	6,20	6,30	4,30	8,90
Sg 112	6	0,92	0,84	0,92	0,25	0,40	Sg 315 S	8	8,40	7,00	7,00	5,00	9,60
Sg 112	8	1,05	0,97	1,05	0,25	0,40	Sg 315 MA	2	3,60	3,00	2,90	1,50	4,80
Sg 132	2	1,02	0,94	1,04	0,17	0,57	Sg 315 MB	2	3,30	2,80	2,90	1,30	4,90
Sg 132	4	1,16	1,04	1,16	0,17	0,57	Sg 315 MA	4	6,20	5,10	4,80	2,90	7,40
Sg 132	6	1,40	1,22	1,37	0,17	0,57	Sg 315 MB	4	5,90	4,90	4,80	2,70	7,50
Sg 132	8	1,63	1,39	1,57	0,17	0,57	Sg 315 MA	6	7,20	6,00	6,20	4,10	9,00
Sg 160	2	1,23	1,09	1,22	0,82	1,07	Sg 315 MB	6	6,80	5,60	6,10	3,60	9,30
Sg 160	4	1,35	1,13	1,32	1,00	1,39	Sg 315 MA	8	8,20	6,80	6,90	4,80	9,70
Sg 160	6	1,61	1,37	1,58	1,26	1,62	Sg 315 MB	8	7,70	6,40	6,80	4,30	10,00
Sg 160	8	1,92	1,50	1,80	1,47	1,80	SEE 315MC	2	2,90	2,50	2,80	1,00	5,10
Sg 180	2	1,90	1,66	1,65	1,00	1,20	SEE 315MC	4	7,50	6,30	4,70	2,60	7,40
Sg 180	4	2,42	1,82	1,98	1,00	1,35	SEE 315MD	6	8,30	6,90	5,30	2,50	9,00
Sg 180	6	2,75	2,07	2,15	1,60	1,95	SEE 315MD	8	9,40	7,80	5,90	3,10	9,60
Sg 180	8	3,30	2,04	2,49	1,90	2,44	SEE 355	adaptation to belt drive on customer's request					
Sg 200 LA	2	2,00	1,60	1,50	1,10	2,10	Sg 355	adaptation to belt drive on customer's request					
Sg 200 LB	2	1,80	1,50	1,50	1,00	2,10	Sh 355	adaptation to belt drive on customer's request					
Sg 200 L	4	2,40	1,90	2,10	1,50	2,90	Sh 400	adaptation to belt drive on customer's request					
Sg 200LA	6	2,80	2,30	2,40	1,80	3,30	Sh 450	adaptation to belt drive on customer's request					
							Sh 500	adaptation to belt drive on customer's request					

Value of radial force  $F_R$  acting on the shaft end for a given belt pulley diameter is calculated according to the following formula:

$$F_R = \frac{19600 \times P \times k}{D_k \times n} \text{ [N]}$$

where: P - motor output [kW]  
 $D_k$  - belt pulley diameter [m]  
 n - speed [rpm]  
 k - belt tension factor:  
 for V-belts  $k=2,2$   
 for flat belts  $k=3$

Value of force  $F_R$  acting on any point of the shaft end (between points  $X=\max$  and  $X=0$ ) may be calculated according to the following formula:

$$F_R = F_{X0} - \frac{X}{E} \times (F_{X0} - F_{XMAX}) \text{ [N]}$$

where:  $F_{X0}$  - value of  $F_R$  force acting on the beginning of the shaft end  
 $F_{XMAX}$  - value of  $F_R$  force acting on the end of the shaft end  
 E - length of the shaft end

## BEARINGS

Frame size	Number of poles	Bearings
Sg 56	2 ÷ 6	6201 2Z
Sg 63	2 ÷ 8	6202 2Z
Sh 71	2 ÷ 8	6203 2Z
Sh 80	2 ÷ 8	6204 2Z
Sh 90	2 ÷ 8	6205 2Z
Sg 100	2 ÷ 8	6206 2Z
Sg 112	2 ÷ 8	6306 2Z
Sg 132	2 ÷ 8	6308 2Z
Sg 160	2 ÷ 8	6309 2Z
Sg 180	2 ÷ 8	6311 2Z
Sg 200	2 ÷ 12	6212 C3
Sg 225	2 ÷ 12	6213 C3
Sg 250	2 ÷ 12	6215 C3
Sg 280	2	6217 C3
Sg 280	4 ÷ 12	6217 C3
Sg 315	2	6315 C3
Sg 315	4 ÷ 12	6318 C3

*The bearings in basic version of motors for horizontal duty.*

Standard motors in frame size 56 ÷ 500 are being cooled down by means of a fan installed on the shaft from the non-drive end, covered with steel cover, cooling system IC 411 according to the IEC 60034-6 standard.

The design of fans and fan covers as well as materials used ensure optimum utilization of their aerodynamic and aeroacoustic properties.

Standard motors can operate in both directions of rotation, with the exception of Sh 355, 400, 450, 500 (2 and 4 poles) motors where unidirectional fans are applied.

## ORDERING INFORMATION

*Orders for motors should specify:*

- motor type designation,
- rated output,
- rated speed,
- operating duty,
- supply voltage and connection,
- frequency,
- mounting arrangements, end shield material,
- degree of protection,
- machine to be driven,
- other details of out-of-catalogue or special version,

*and information concerning additional accessories e.g.*

- thermal protection,
- anticondensation heaters,
- vibration sensors,
- etc.

Frame size	Number of poles	Bearings	
Sg 315 MC	DE NDE	6 ÷ 8	NU320 EM1 6320 C3
SEE 315		2	6315 2ZC3
SEE 315	DE NDE	4 ÷ 8	6320 2ZC3 6318 2ZC3
Sg 355		2	6317 C3
Sg 355	DE NDE	4 ÷ 12	NU322 C3 6322 C3
SEE 355		2	6217 C3
SEE 355		4 ÷ 8	6222 C3
Sh 355		2	6217 C3
Sh 355		4 ÷ 8	6322 C3
Sh 400		2	6218 C3
Sh 400	DE NDE	4 ÷ 8	6324 MC3 6322 MC3
Sh 450	DE NDE	4 ÷ 10	6324 MC3 NU222 EM1
Sh 500	DE NDE	4 ÷ 10	NU226 EM1+ 6226 C3 NU226 EM1

*DE - drive end NDE - non drive end*

*When ordering high-power or special purpose motors one should also indicate:*

- required direction of rotation,
- required degree of interior protection,
- method of start-up,
- method of coupling with the driven unit (gears, dimensions of belt pulleys, etc.),
- type of driven machine (nature of load), including the moment of inertia J or flywheel effect GD<sup>2</sup> brought to the motor shaft,
- other customer's specifications.

*When ordering spare parts one should specify:*

- full designation of the motor type including its serial number (provided on the nameplate) or catalogue number,
- degree of protection,
- mounting form,
- name of part,
- number of pieces.