

*Three-phase
squirrel-cage
series*

SCe 315-355
open-drip proof IP23



BASIC EXECUTION - GENERAL CHARACTERISTICS

Open-rip proof motors IP23 SCe series can operate only indoors where ambient air does not contain dust or other mechanical or chemical pollutants. Air dustiness can not be greater than 2mg/m. These motors are of general industrial use. They are used for driving machines and equipment of continuous duty without frequent starting and reversing. The basic SCe series includes motors of mechanical size 315,355 and 400.

Series / Frame size	SCe 315; 355; 400
Ratings	according to technical data
Duty type	continuous, S1
Voltage and frequency	380/660V; 50Hz (other voltages on request)
Class of insulation	F
Ambient temperature	-20 C° ... +40 C°
Altitude	up to 1000 m above sea level
Degree of protection	IP23 (terminal box IP55) – acc. to IEC 34-5
Method of cooling	IC01 – acc. to EN 60034-6
Type of construction	IM1001 (B3) – acc. to EN 60034-7
Starting	direct on line, “star-delta” starter or softstart
Number of terminals	6
Location of main terminal box	right – viewed from DE (turned 4×90°) (left – on request)
Bearings	anti-friction (bearings types acc. to tabel 1)
Direction of rotation	both
Noise level	acc. to IEC 34-9
Vibration severity grade	N (≤2.8 mm/s) acc. to IEC 34-14
Thermal winding protection	3xPTC Mark A (on request - Pt100 platinum sensors)
Thermal bearing protection	on request
Space heaters	on request
Adapted to frequency invert supply	on request
Insulated bearing chamber	on request
Paint finish	blue - RAL 5010
Material of frame	cast-iron
Corrosive protection	for normal ambient conditions (on request – for marine conditions, tropic TA and tropic TH)
Standard	IEC 34-1

CHANGES IN AMBIENT AND SUPPLY CONDITION

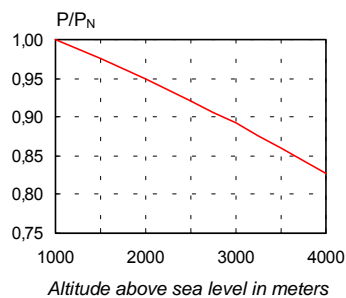
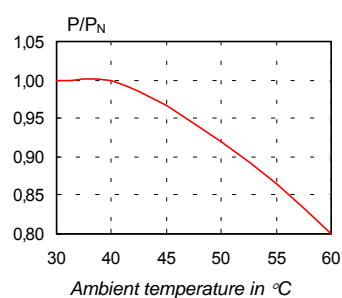

Rated motor load is specified at ambient temperature +40°C and operational altitude up to 1000 m above sea level. When temperature and / or altitude are changed motor output should be corrected according to the below characteristics.

Corrected output can be obtained by multiplying rated output by correction factors read from the below characteristics. Motor output should also be corrected due to supply changes. Corrected output can be calculated by multiplying nominal output by Voltage correction factor from the below table.

Frequency [Hz]	Voltage correction factor:						
	0,8 U _N	0,9 U _N	0,95 U _N	1,0 U _N	1,05 U _N	1,1 U _N	1,2 U _N
50	0,8	0,9	1,0	1,0	1,0	-	-
60	-	0,9	1,0	1,0	1,0	1,05	1,1

BALANCING AND ALLOWABLE VIBRATION LEVEL

Motor's rotor is balanced with half-key installed in free shaft extension. Permissible vibration speed of uncoupled motor is 2.8 mm/s rms.

BEARINGS

STANDARD

TABLE 1

Mechanical size	No. of poles, 2p	D.E. bearing	N.D.E. bearing
SCe 315	2	6316 C3	6316 C3
	4÷12	NU320 EM1	6320 C3
SCe 355	2	6317 C3	6317 C3
	4÷12	NU322 EM1	6322 C3
SCe 400	6÷12	NU324 EM1	6324 C3

It is permissible to use equivalent bearings. Bearing lubricant - solid grease ŁT-4S3 (Mobilux EP3)

THERMAL WINDING PROTECTION

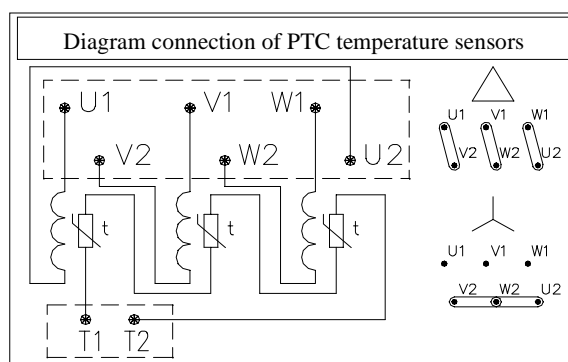

TECHNICAL DATA:

380V(Δ); 50Hz

Item	Motor type	Rated power	Rated speed	Rated current	Power factor	Efficiency	Starting current	Starting torque	Breakdown torque	Rotor inertia	Mass	Sound pressure level
		P_N	n_N	I_N	$\cos\varphi$	η	I/I_N	T_i/T_N	T_b/T_N	J	m	$Ld_1(A)$
		kW	rpm	A	-	%	-	-	-	kgm ²	kg	dB(A)

3000 rpm (2p=2)												
1.	SCe 315 S2	160	2954	292	0,89	93,5	5,3	1,4	2,3	2,5	775	85
2.	SCe 315 M2	200	2956	363	0,89	94,1	5,6	1,5	2,3	3,0	850	85
3.	SCe 315 M2B	250	2954	453	0,89	94,2	5,6	1,5	2,3	3,0	850	85
4.	SCe 355 S2	250	2963	465	0,87	94,4	4,5	1,2	2,1	4,0	970	87
5.	SCe 355 M2	315	2966	579	0,87	95,0	5,0	1,4	2,1	4,4	1070	87
6.	SCe 355 M2sp	355	2960	663	0,86	94,7	4,6	1,2	1,7	4,4	1070	87
1500 rpm (2p=4)												
7.	SCe 315 S4	160	1475	299	0,87	93,5	5,0	1,2	2,1	3,48	820	85
8.	SCe 315 M4	200	1475	372	0,87	94,0	5,0	1,2	2,1	3,9	880	85
9.	SCe 355 S4	250	1477	454	0,89	94,1	5,7	1,3	2,1	5,58	1040	86
10.	SCe 355 M4	315	1478	569	0,89	94,7	6,0	1,4	2,2	6,31	1150	86
1000 rpm (2p=6)												
11.	SCe 315 S6	110	982	211	0,86	92,2	5,0	1,2	2,0	4,5	800	80
12.	SCe 315 M6	132	982	251	0,86	93,0	5,0	1,2	2,1	5,1	880	80
13.	SCe 355 S6	160	980	297	0,88	93,1	6,1	1,6	2,5	7,52	1000	82
14.	SCe 355 M6	200	980	370	0,88	93,5	6,2	1,7	2,5	8,32	1080	84
15.	SCe 400 S6A	250	985	474	0,85	94,2	5,8	1,5	2,2	11,5	1500	84
16.	SCe 400 S6B	315	986	586	0,86	94,7	5,6	1,6	2,3	14,0	1630	84
750 rpm (2p=8)												
17.	SCe 315 S8	90	738	175	0,84	93,1	6,1	1,7	2,1	4,65	800	80
18.	SCe 315 M8	110	738	214	0,84	93,1	6,1	1,7	2,1	5,26	880	80
19.	SCe 355 S8	132	735	257	0,84	93,0	5,0	1,5	1,9	8,72	1010	81
20.	SCe 355 M8	160	736	310	0,84	93,6	5,3	1,6	2,0	9,95	1100	81
21.	SCe 400 S8A	200	736	394	0,83	93,0	5,3	1,4	1,8	17,0	1350	82
22.	SCe 400 S8B	250	736	490	0,83	93,5	5,3	1,4	1,8	20,0	1500	82
23.	SCe 400 M8A	315	736	614	0,83	93,9	5,3	1,4	1,8	22,5	1650	82
600 rpm (2p=10)												
24.	SCe 315 S10	55	589	113	0,80	92,0	6,0	1,6	2,4	5,1	800	78
25.	SCe 315 M10	75	589	155	0,80	92,0	6,0	1,6	2,4	5,78	880	78
26.	SCe 355 S10	90	588	182	0,81	93,0	5,0	1,4	1,9	9,0	1000	80
27.	SCe 355 M10A	110	588	222	0,81	93,1	5,0	1,4	1,9	9,97	1070	80
28.	SCe 355 M10B	132	582	272	0,80	92,0	4,7	1,35	1,8	10,5	1120	80
29.	SCe 400 S10	160	587	310	0,84	93,2	4,8	1,2	2,0	19,0	1420	82
30.	SCe 400 M10A	200	587	386	0,84	93,7	5,0	1,25	2,1	21,9	1600	82
31.	SCe 400 M10B	250	587	482	0,84	93,8	5,2	1,3	2,1	25,3	1720	82
500 rpm (2p=12)												
32.	SCe 355 S12	75	488	158	0,79	91,7	4,5	1,2	1,8	9,33	1000	78
33.	SCe 355 M12	90	488	188	0,79	92,0	4,5	1,2	1,8	10,58	1100	78
34.	SCe 400 S12A	110	486	227	0,80	92,0	4,25	1,2	1,7	14,87	1450	80
35.	SCe 400 S12B	132	488	271	0,80	92,5	4,8	1,25	1,85	22,55	1600	80
36.	SCe 400 M12A	160	487	323	0,81	93,0	4,4	1,2	1,75	25,3	1750	80
37.	SCe 400 M12B	200	489	408	0,80	93,0	5,0	1,5	2,0	29,9	1950	81



DIMENSIONAL DRAWING OF MOTORS SCe 315-400 SERIES

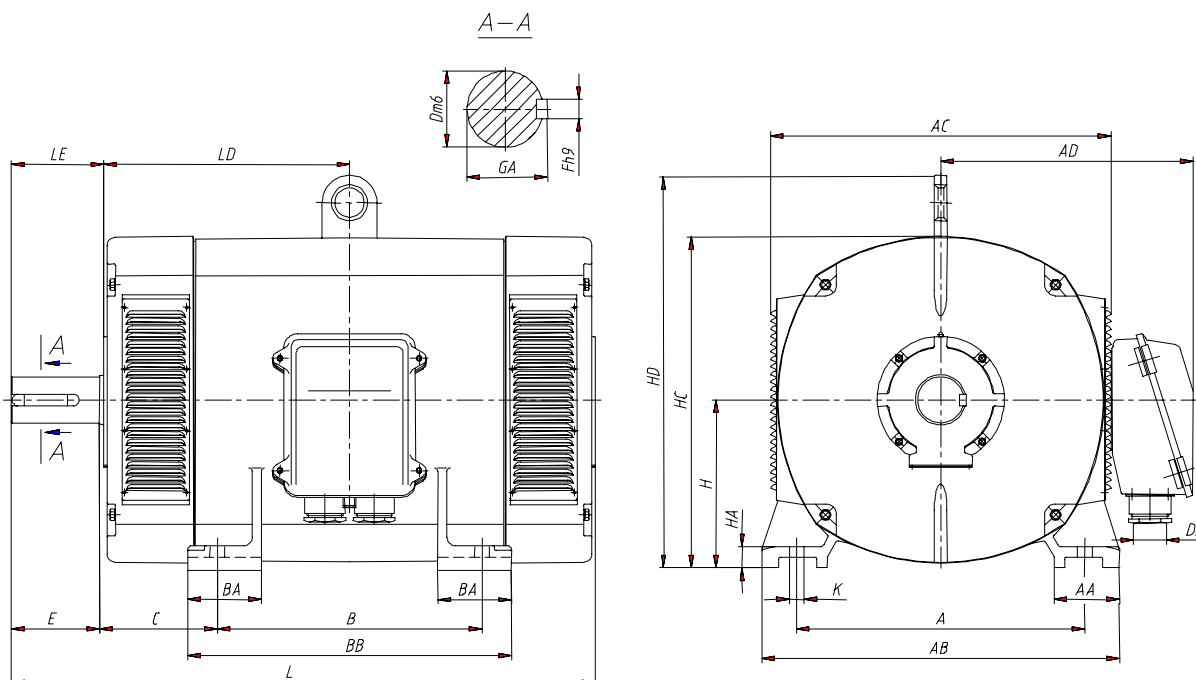

Mechanical construction IM1001 (B3)

Motor type	2p	A	B	C	D	E	F	GA	H	HA	K	AA	AB	AC	AD	AE	BA	BB	HC	HD	L	LD	LE	DB	NG
SCe 315 S	2	508	406	216	70	140	20	75	315	30	28	130	620	637	480	318	120	490	620	718	974	409	150	54	M20
SCe 315 S	4÷10	508	406	216	90	170	25	95	315	30	28	130	620	637	480	318	120	490	620	718	1006	589	180	54	M24
SCe 315 M	2	508	457	216	70	140	20	75	315	30	28	130	620	637	480	318	120	540	620	718	1025	435	150	54	M20
SCe 315 M	4÷10	508	457	216	90	170	25	95	315	30	28	130	620	637	480	318	120	540	620	718	1056	615	180	54	M24
SCe 355 S	2	610	500	254	80	170	22	85	355	35	28	130	730	700	505	350	130	590	695	810	1173	494	180	54	M20
SCe 355 S	4÷12	610	500	254	100	210	28	106	355	35	28	130	730	700	505	350	130	590	695	810	1214	494	220	54	M24
SCe 355 M	2	610	560	254	80	170	22	85	355	35	28	130	730	700	505	350	130	650	695	810	1233	524	180	54	M20
SCe 355 M	4÷12	610	560	254	100	210	28	106	355	35	28	130	730	700	505	350	130	650	695	810	1274	524	220	54	M24
SCe 400 S	6÷12	686	560	280	110	210	28	116	400	50	35	155	850	790	601	405	175	700	790	920	1320	550	220	54	M24
SCe 400 M	6÷12	686	630	280	110	210	28	116	400	50	35	155	850	790	601	405	175	770	790	920	1390	585	220	54	M24

Remark: Shaft extension has centre hole threaded NG (dimensioned according to ISO/R 775-1969)

NOTE !

The Manufacturer reserves the right to change operational characteristics and dimensions in the course of motors design modernisation.