



BESEL S.A.

FABRYKA SILNIKÓW ELEKTRYCZNYCH

SILNIKI INDUKCYJNE TRÓJFAZOWE ENERGOOSZCZĘDNE klasy IE4

Charakterystyka silników katalogowych:

- silniki ogólnego przeznaczenia do pracy w warunkach klimatu umiarkowanego,
- praca ciągła S1,
- napięcia znamionowe 230V/400V (Δ/Y),
- częstotliwość zasilania 50 Hz,
- temperatura otoczenia od -30°C do $+60^{\circ}\text{C}$,
- kolor malowania RAL 5010.



THREE-PHASE INDUCTION MOTORS ENERGY EFFICIENT MOTORS class IE4

Description of the catalogue motors:

- general purpose motors; temperate climate,
- duty S1,
- rated voltage 230V/400V (Δ/Y),
- frequency 50 Hz,
- ambient temperature from -30°C to $+60^{\circ}\text{C}$,
- standard paint colour RAL 5010.

stopień ochrony: IP54 (IP55; IP56; IP65)
klasa izolacji F

degree of protection: IP54 (IP55; IP56; IP65)
insulation class F

Typ	Moc		Prędkość obrotowa [min ⁻¹]	Prąd [A] przy		Sprawność η [%] przy obciążeniu			Współczynnik mocy $\cos \varphi_N$	Moment znamionowy M_N [Nm]	Krotność prądu rozruchowego I_r/I_N	Krotność momentu rozruchowego M_r/M_N	$\frac{M_{max}}{M_N}$	Moment bezwładności J [kgm ²]	Masa [kg]
	[kW]	[KM]		230 V Δ	400 V Y	100%	75%	50%							
Frame size	Rated output		Rated speed [min ⁻¹]	Rated current [A] at		Efficiency η [%] at % of full load			Power factor $\cos \varphi_N$	Torque T_N [Nm]	Starting current/ rated current I_L/I_N	Starting torque/ rated torque T_L/T_N	$\frac{T_b}{T_N}$	Moment of inertia J [kgm ²]	Motor weight [kg]
	[kW]	[HP]		230 V Δ	400 V Y	100%	75%	50%							

Silniki 2-biegunowe, 3000 min⁻¹; 50Hz

2-pole motors, 3000 min⁻¹; 50Hz

4SIE 63-2A	0,18	0,25	2880	0,95	0,55	70,8	71,0	66,0	0,68	0,6	3,9	3,4	3,6	0,000235	4,1
4SIE 63-2B	0,25	0,33	2840	1,10	0,60	74,3	74,5	70,0	0,75	0,86	3,3	2,4	2,5	0,000310	5,0
4SIE 71-2A	0,37	0,50	2920	1,65	0,95	78,1	78,0	75,0	0,72	1,2	8	4,5	5	0,000691	7,8
4SIE 71-2B	0,55	0,75	2870	2,15	1,25	81,5	80,5	77,0	0,78	1,85	7,3	3,8	4	0,000820	10,6
4SIE 80-2A	0,75	1,00	2940	3,1	1,8	83,5	83,0	79,0	0,7	2,45	11	6,4	6,4	0,001422	11,9
4SIE 80-2B	1,10	1,50	2900	4	2,3	85,2	84,5	81,0	0,81	3,6	7,6	3,9	4	0,001673	13,0

Silniki 4-biegunowe, 1500 min⁻¹; 50Hz

4-pole motors, 1500 min⁻¹; 50Hz

4SIE 63-4A	0,12	0,17	1425	0,7	0,41	69,8	70,0	64,0	0,61	0,8	4,2	2,8	3,2	0,000451	5,1
4SIE 63-4B	0,18	0,25	1430	1	0,65	74,7	75,0	70,0	0,53	1,2	4,6	3,2	3,4	0,000495	6,0
4SIE 71-4A	0,25	0,33	1420	1,4	0,80	77,9	75,0	68,0	0,58	1,68	4,4	3,0	3,1	0,001236	7,9
4SIE 71-4B	0,37	0,50	1410	2,1	1,20	81,1	81,0	78,0	0,56	2,50	4,1	3,6	3,4	0,001305	9,6
4SIE 80-4A	0,55	0,75	1440	2,4	1,4	83,9	83,5	80,0	0,67	3,65	6,9	4,3	4,2	0,002655	11,5
4SIE 80-4B	0,75	1,00	1435	3,3	1,9	85,7	84,0	80,0	0,68	5	7	4,5	4,4	0,003123	12,7

Silniki odpowiadają wymaganiom normy IEC 60034-30.

Motors meet requirements of Standard IEC 60034-30.

Silniki odpowiadają wymaganiom Polskiej Normy PN-EN 60034-1 oraz normom międzynarodowym IEC 60034-1.

Wszystkie silniki posiadają znak CE.

Motors meet requirements of Polish Standard PN-EN 60034-1 and the international rules IEC 60034-1.

All motors are provided with CE mark.

Silniki na łapach
Forma wykonania
IMB3

Foot - mounted motors
Type of construction
IMB3

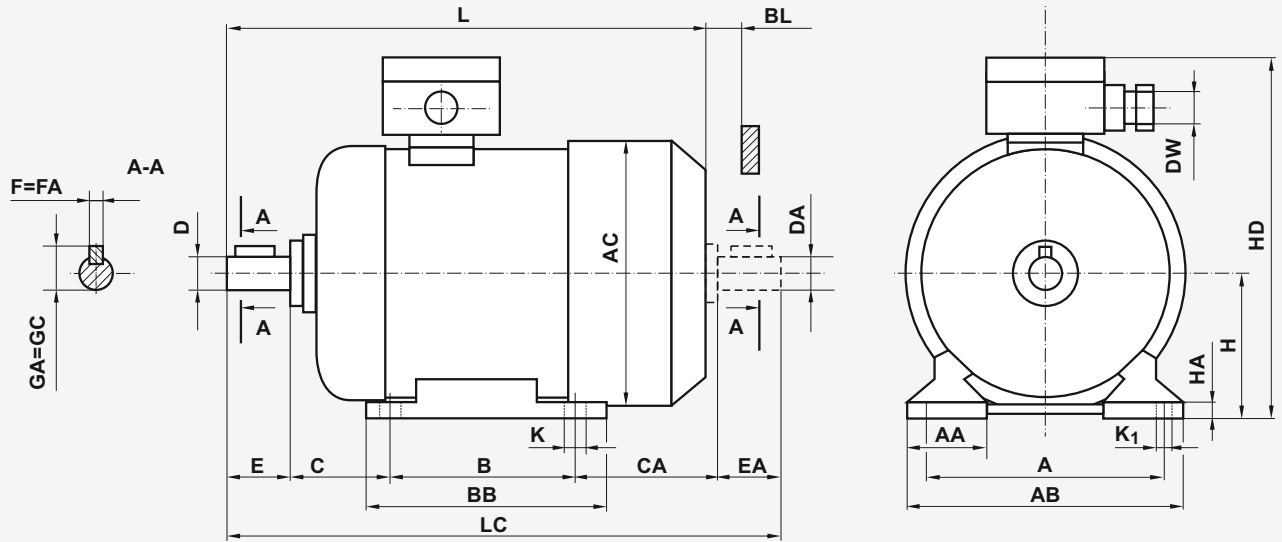

Forma wykonania IMB3

Type of construction IMB3

Typ	Wymiary (mm)																Dimensions (mm)				Łożyska Bearings	
	A	B	C	CA	D=DA	E=EA	F=FA	GA=GC	H	K	K ₁	DW	AA	AB	AC	BB	BL _{min}	HA	HD	L		LC
4SIE 63-2A	100	80	40	79	11j6	23	4h9	12,5	63 _{0,5}	7	10	M20	36	124	126	106	11	8,5	166	210	242	6202 2Z
4SIE 63-2B	100	80	40	79																236	268	
4SIE 63-4A	100	80	40	79																264	302	
4SIE 63-4B	100	80	40	79	14j6	30	5h9	16	71 _{0,5}	7	10	M20	45	142	141	116	12	8	182	284	322	6203 2Z
4SIE 71-2A	112	90	45	106																284	322	
4SIE 71-2B	112	90	45	106																306	357	
4SIE 71-4A	112	90	45	106	19j6	40	6h9	21,5	80 _{0,5}	10	13	M20	55	160	157	130	15	9	199	318	369	6204 2Z
4SIE 80-2A	125	100	50	120																306	357	
4SIE 80-2B	125	100	50	138																318	369	
4SIE 80-4A	125	100	50	120																306	357	
4SIE 80-4B	125	100	50	138	318	369																

Silniki kołnierowe
Formy wykonania
IMB5, IMB14

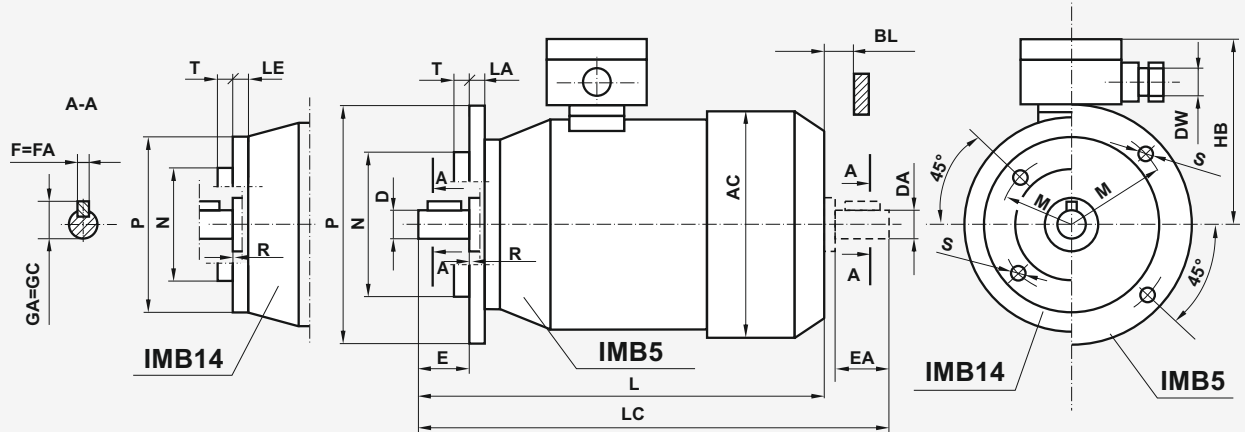

Flange
- mounted motors
Types of construction
IMB5, IMB14

Forma wykonania IMB5

Type of construction IMB5

Typ Frame size	Wymiary (mm)										Dimensions (mm)							Łożyska Bearings	
	Kołnierz Flange	P	M	N	S	D= DA	E= EA	F= FA	GA= GC	LA	T	R	DW	AC	BL min	HB	L		LC
4SIEK 63-2A	B5	140	115	95j6	10	11j6	23	4h9	12,5	9	3	0	M20	126	11	103	210	242	6202 2Z
4SIEK 63-2B																	236	268	
4SIEK 63-4A																	236	268	
4SIEK 63-4B																	236	268	
4SIEK 71-2A	B5	160	130	110j6	10	14j6	30	5h9	16	9	3,5	0	M20	141	12	111	264	302	6203 2Z
4SIEK 71-4A																	284	322	
4SIEK 80-2A	B5	200	165	130j6	12	19j6	40	6h9	21,5	10	3,5	0	M20	157	15	119	306	357	6204 2Z
4SIEK 80-2B																	318	369	
4SIEK 80-4A																	306	357	
4SIEK 80-4B																	318	369	

Silniki kołnierzowe
Formy wykonania
IMB5, IMB14

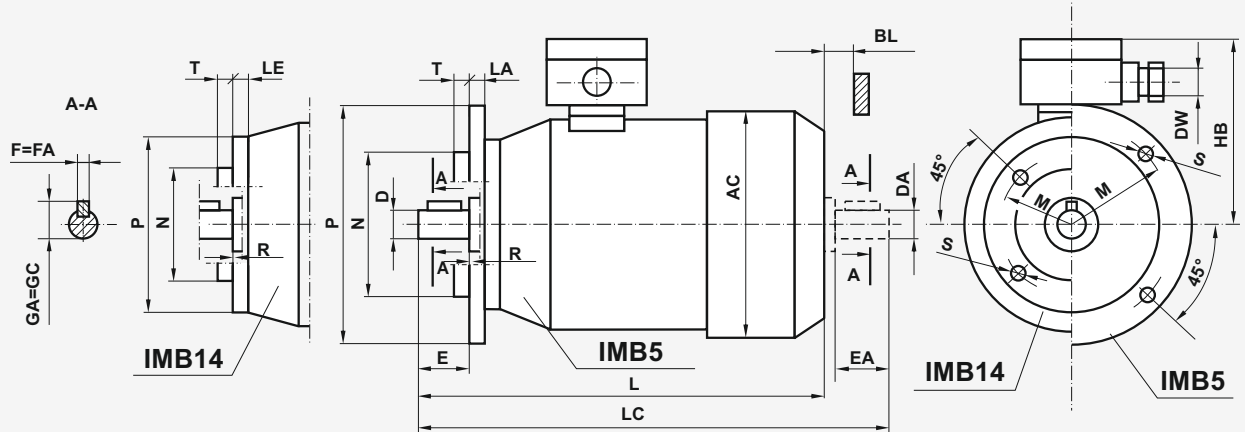

Flange
- mounted motors
Types of construction
IMB5, IMB14

Forma wykonania IMB14

Type of construction IMB14

Typ Frame size	Wymiary (mm)										Dimensions (mm)								Łożyska Bearings
	Kołnierz Flange	P	M	N	S	D=DA	E=EA	F=FA	GA=GC	LE	T	R	DW	AC	BL min	HB	L	LC	
4SIEK 63-2A1	B14/1	120	100	80j6	M6	11j6	23	4h9	12,5	14	3	0	M20	126	11	102	210	242	6202 2Z
4SIEK 63-2A2	B14/2	90	75	60j6	M5					9,5	2,5								
4SIEK 63-2B1	B14/1	120	100	80j6	M6					14	3								
4SIEK 63-2B2	B14/2	90	75	60j6	M5					9,5	2,5								
4SIEK 63-4A1	B14/1	120	100	80j6	M6					14	3								
4SIEK 63-4A2	B14/2	90	75	60j6	M5					9,5	2,5								
4SIEK 63-4B1	B14/1	120	100	80j6	M6					14	3								
4SIEK 63-4B2	B14/2	90	75	60j6	M5					9,5	2,5								
4SIEK 71-2A1	B14/1	140	115	95j6	M8	14j6	30	5h9	16	14	3	0	M20	141	12	111	264	302	6203 2Z
4SIEK 71-2A2	B14/2	105	85	70j6	M6					9,5	2,5								
4SIEK 71-2B1	B14/1	140	115	95j6	M8					14	3								
4SIEK 71-2B2	B14/2	105	85	70j6	M6					9,5	2,5								
4SIEK 71-4A1	B14/1	140	115	95j6	M8					14	3								
4SIEK 71-4A2	B14/2	105	85	70j6	M6					9,5	2,5								
4SIEK 71-4B1	B14/1	140	115	95j6	M8					14	3								
4SIEK 71-4B2	B14/2	105	85	70j6	M6					9,5	2,5								
4SIEK 80-2A1	B14/1	160	130	110j6	M8	19j6	40	6h9	21,5	14	3,5	0	M20	157	15	119	306	357	6204 2Z
4SIEK 80-2A2	B14/2	120	100	80j6	M6					12	3								
4SIEK 80-2B1	B14/1	160	130	110j6	M8					14	3,5								
4SIEK 80-4A1	B14/1	160	130	110j6	M8					14	3,5								
4SIEK 80-4A2	B14/2	120	100	80j6	M6					12	3								
4SIEK 80-4B1	B14/1	160	130	110j6	M8					14	3,5								
4SIEK 80-4B2	B14/2	120	100	80j6	M6					12	3								

Producent zastrzega sobie możliwość zmian danych zawartych w karcie katalogowej wynikających z ciągłego doskonalenia wyrobu.

As part of our development program, we reserve the right to alter or amend any of the specifications without giving prior notice.