



FACTORY OF ELECTRIC APPARATUS

EMA – ELFA Sp. z o.o.

st Poczтова 7, 63-500 Ostrzeszów, PL

phone: +48 62 730 30 51

fax: +48 62 730 33 06

handel@ema-elfa.pl

www.ema-elfa.pl

Cantoni®
GROUP

ELECTROMAGNETIC DISC BRAKES

H SERIES



Spring actuated and electromagnetically released disk brake type H powered by direct current. Designed for braking rotating machine parts. Utilized as safety brake. High repeatability even with large number of actuations. The brake characterizes relatively simple construction, facility for regulating brake parameters such as braking torque, braking time and also possibility of supply from alternating current source after connecting up a rectifier circuit delivered at customer's request along with the brake. Direct current disk brake – consisting of electromagnet , armature with friction lining and iron fan. When the brake is actuated , the armature moves forward , simultaneously releasing the fan keyed to the shaft to rotate freely. When the electromagnet is switched off, the armature gets moved by a spring to the fan stopping the shaft of the cooperating machine. Used wherever rotating part of machine is to be immobilized for safety reasons , e.g. woodworking machine.



Advantages:

-Compact construction, gentle braking, quiet work, simple installation, easy operation

They are designed for braking rotating parts of machines and their task is:

- ❖ emergency stopping, in order to ensure drive safety functions,
- ❖ immobilizing machine actuators,
- ❖ minimizing run-on times of drives (to meet safety requirements according to Office of Technical Inspection (UDT) regulations)
- ❖ built onto an electric motor, the brake provides a self-braking motor, a drive unit meeting the requirements of utilisation safety and positioning.

Brakes can be manufactured in variants suitable for various direct-current voltages: 24V, 104V, 180V, 207V which allows them to be supplied from standard alternating current sources, through appropriate rectifier

Parameters		Unit	Brake type							
			H 63	H 71	H 80	H 90	H100	H112	H132	H160
Supply voltage	Un	[V]	24, 104, 180, 207							
Power	P _{20°}	[W]	18	18	25	25	40	40	40	60
Max. speed	n _{max.}	min ⁻¹	3000							
Braking torque	M _h	Nm	3	4	7	7	13	13	13	30
Weight	G	kg	0,6	0,8	1,3	1,6	2,1	3,4	4,2	5,8

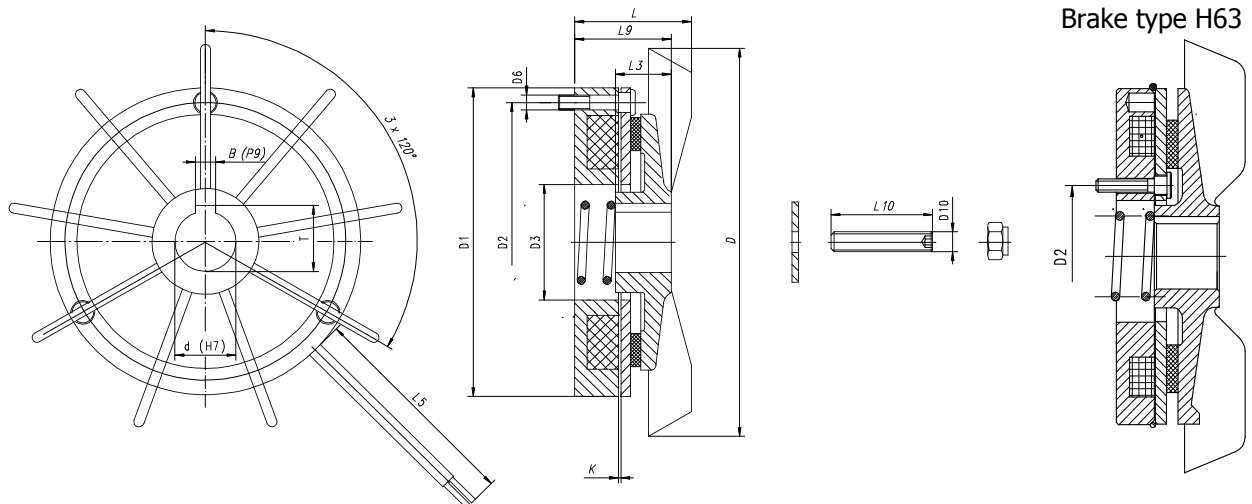

Type	D	D1	D2	D3	D6	D10	L	L3	L5	L9	L10	d	B	T	K
H63	102	92	43	30	3xM5	M8	31	17	430	25	25	15	5	17,3	0,2
H71	116	103	93	30	3xM5	M8	37	20	430	32	25	17	5	19,3	0,2
H80	143	126	116	45	3xM5	M8	40	22	430	35	40	20	6	22,8	0,2
H90	155	126	116	45	3xM5	M8	41	22	430	35	40	25	8	28,3	0,2
H100	170	154	139	60	3xM6	M10	45	26	430	38	40	30	8	33,3	0,2
H112	182	154	139	60	3xM6	M10	46	28	430	41	40	35	10	38,3	0,2
H132	213	154	139	60	3xM6	M10	52	30	430	45	40	35	10	38,3	0,2
H160	250	200	178	80	3xM8	M10	65	40	430	55	40	35	10	38,3	0,2

ELECTRICAL EQUIPMENT

A number of modules, ranging from simple circuits with classic designs, to complex assemblies ensuring quick action and drives positioning have been designed to drive the brakes. Relevant brake applications with switching in the primary or secondary circuits are ensured by half- or full-wave rectifiers and fast electronic circuits. The manufacturer recommends to use as low alternating current voltages as possible to supply the brakes. Appropriate choice of the control voltage will prevent or at least limit surges that may occur in power supply circuits. It is not recommended to use extensively long control wiring, which would be a source of harmful surges.

Rectifier B2-1P

The B2-1P rectifiers series forms a complete wave rectifier unit for direct installation. The terminal strip provided facilitates installation and connection to the circuit.

RECTIFIER PARAMETERS			
		B2-1P-400	B2-1P-600
Maximum input voltage (alternating voltage AC)	U_{IN}	400 VAC	600 VAC
Maximum output voltage (direct voltage DC)	U_{OUT}	$0,45 U_{IN}$	$0,45 U_{IN}$
Maximum continuous output current rectifier	I_{OUT}	2A	2A

For example

Maximum input voltage (alternating voltage) - $U_{IN} = 230VAC$,

The resulting output voltage of the rectifier (direct voltage) - $0,45 U_{IN} = 0,45 \times 230 = 104VDC$

Rectifier B2-2P

The B2-2P rectifiers series forms a complete full-wave rectifier unit for direct installation. The terminal strip provided facilitates installation and connection to the circuit. The rectifier allows feeding input voltage max. 400VAC, 2A which after rectification provides DC voltage of value equal to 0,9 input voltage.

RECTIFIER PARAMETERS		
Maximum input voltage (alternating voltage AC)	U_{IN}	250 VAC
Maximum output voltage (direct voltage DC)	U_{OUT}	$0,9 U_{IN}$
Maximum continuous output current rectifier	I_{OUT}	2A

For example

Maximum input voltage (alternating voltage) - $U_{IN} = 230VAC$,

The resulting output voltage of the rectifier (direct voltage) - $0,9 U_{IN} = 0,9 \times 230 = 207VDC$

Rectifiers dimensions

B2-1P-400, B2-2P

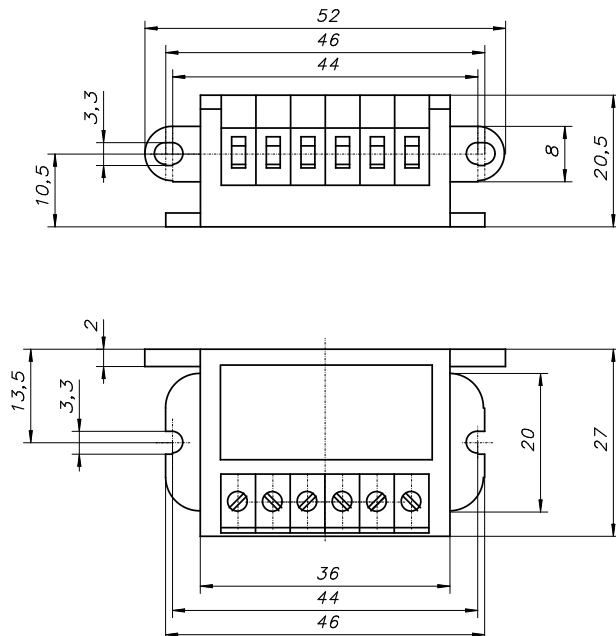

B2-1P-600

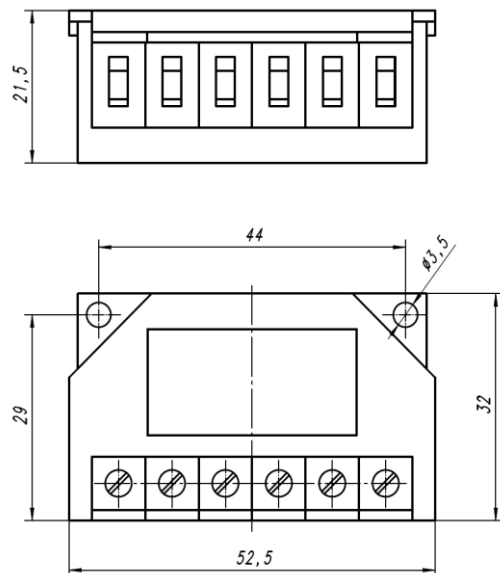

Disconnection of power supply on AC side

The diagram presents connection of rectifiers to supply circuit of motor. When disconnecting the voltage, the magnetic field causes the coil current to flow further through the rectifying diodes and drops slowly. The magnetic field reduces gradually causing prolonged time of braking action and consequently delayed increase of braking torque. If action time is irrelevant, brake should be connected on the AC side. When switching off, the supply circuits act as rectifying diodes.

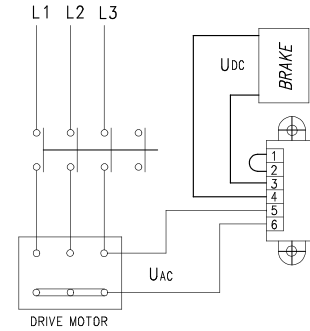

Disconnection of power supply on DC side

The diagram presents connection of rectifiers into electric motor circuit. The coil current is interrupted between the coil and supply (rectifier) circuit. The magnetic field reduces very quickly, **giving short time of braking action and consequently rapid growth of braking torque**. When switching off on DC voltage side, a high peak voltage is generated in the coil causing faster wear of contacts due to sparking. For protecting the coil against peak voltages and protecting the contacts against excessive wear, the rectifier circuit is provided with protective facility allowing brake connection on DC voltage side.

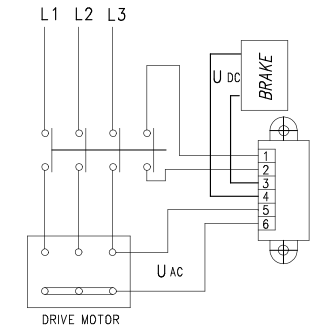

Order denotation

H



.



Nm



d



MECHANICAL SIZE
63, 71, 80, 90, 100, 112, 132, 160

OPERATING VOLTAGE
24, 104, 180, 207 VDC

NOMINAL BRAKING TORQUE [Nm]							
H63	H71	H80	H90	H100	H112	H132	H160
3	4	7		13		30	

EXAMPLE:

H100. 13Nm 180VDC d30

**DIAMETER OF SLEEVE GEAR
d(H7)***

*) standard diameter **d** listed in the table, other diameter after consultation with the producer

**The producer reserves the right to modify as a result of developing the product.
It is possible to realize special versions.**