



FABRYKA APARATURY ELEKTRYCZNEJ

EMA – ELFA Sp. z o.o.

ul. Pocztowa 7, 63-500 Ostrzeszów

tel.: +48 62 730 30 51

fax: +48 62 730 33 06

handel@ema-elfa.pl

www.elfa.cantoni.com.pl

Cantoni[®]
GROUP

ELECTROMAGNETIC DISC BRAKES

HEX SERIES

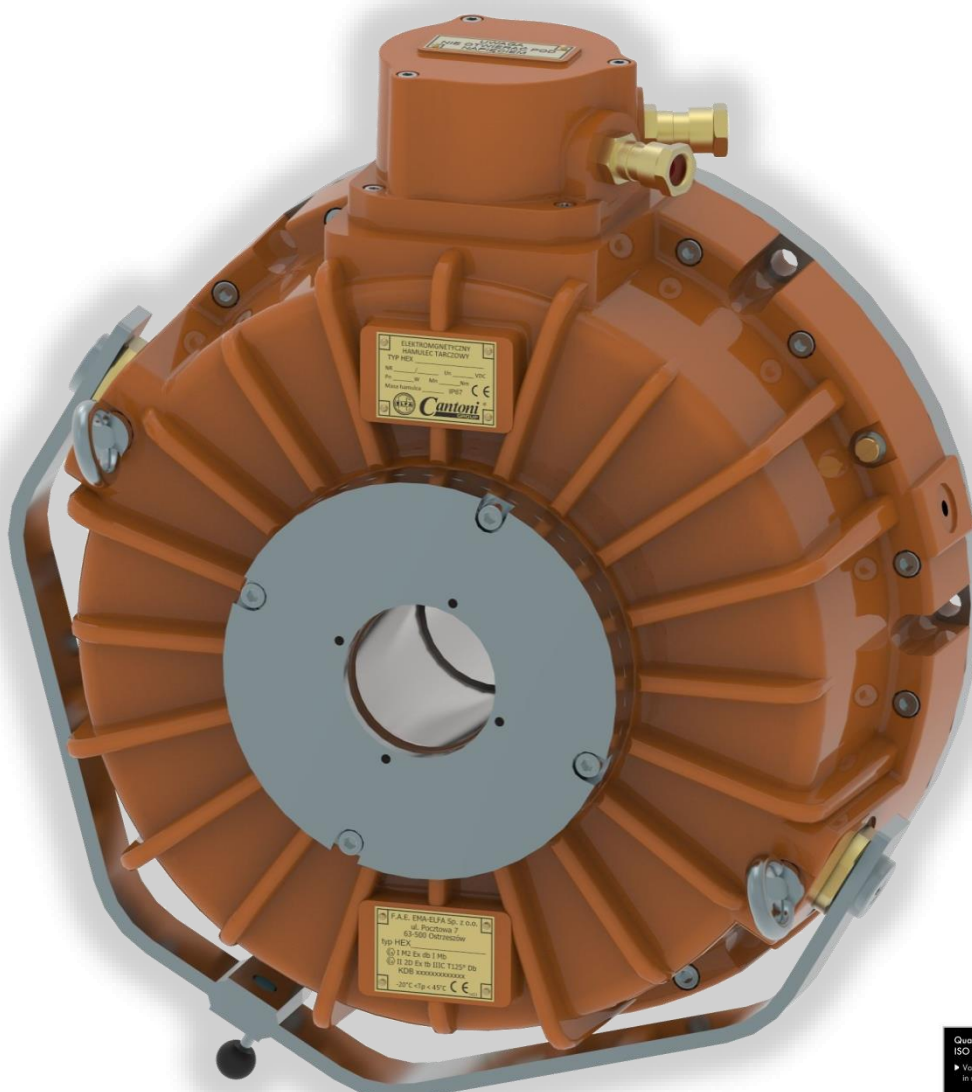

EXPLOSION-PROOF VERSION





HEX series explosion-proof constant current electromagnetic brakes, switched on by spring-loaded with electromagnetic release. Intended for rotating machine parts stopping and precise positioning. Can be used for positioning and as an safety brakes. These brakes are designed, built and tested in conformance with requirements of ISO 9001 and ISO 14001 quality management standards. Our products, described in this information sheet, have CE marks, which means that they are compatible with EU safety-related directives. HEX series brakes meets essential requirements for protective equipment and systems intended for use in areas subject to gas and dusts explosion hazard (2014/34/UE ATEX Directive), which is confirmed by a notified certificate. Our brakes are certified for:



**Methane and coal dust explosion protection for group I devices, category M2,
Dusts explosion protection for group II devices, category 2D:**

-  I M2 Ex db [ia] I Mb
-  II 2D Ex tb [ia] IIIC T125°C Db

Gases and dusts explosion protection for group II devices, category 2G / 2D:

-  II 2G Ex db [ia] IIB T4 Gb
-  II 2D Ex tb [ia] IIIC T125°C Db

HEX series brakes feature high repeatability, also at high operating rates. They can be powered from alternating current sources through a built-in rectifier. Brakes are optionally equipped with manual release levers to allow their emergency releasing. An additional feature is their stable operation, which is particularly important if a machine is powered by several drives, working at high on-off rates. Brake design guarantees simple and trouble-free installation. Various versions are available with different equipment, brake power supply types, allowing users to select the right option for their needs. Built on the electric motor brake together form a motor self-locking, powertrain meets the requirements for safety and positioning drive.

It is intended for stopping rotating machine parts, which can be used for:

- emergency stopping for ensure safety functions,
- Immobilizer actuators acting as a positioning device,
- Reduction of the drive range to a minimum (safety considerations supported by UDT regulations),

Application areas:

- Underground mining and open-cast mining
- Chemical industry
- Petrochemical and refinery industry
- Motor with brake – explosion proof self-braking motor
- Brake reducer - explosion proof kit
- Lifts, cranes and winches working in explosive areas



Parameter		Unit	Brake type							
			HEX 05	HEX 10	HEX 15	HEX 25	HEX 50	HEX 100	HEX 160	
Supply voltage	Un	[V]	24, 104, 180 DC				24, 104, 180 DC; 230,400 AC;			
Power	P _{20°}	[W]	60	60	86	86	140	250	340	
Max. speed	n _{max.}	min ⁻¹	3000			2500		1800		
Braking torque	M _h	Nm	50	100	150	250	500	1000	1600	
Weight	m	kg	28	33	46	90	100	135	170	
Ambient temperature		°C	-20 ÷ +45							
Level of protection		-	IP 67							
Operating time*	on direct voltage side	t ₀₁	ms	300	300	400	400	500	500	600
		t ₀₉	ms	110	110	200	200	270	300	500
	on alternating voltage side	t ₀₁	ms	300	300	400	400	500	500	600
		t ₀₉	ms	Brake disconnection on alternating current side causes about five-times growth in braking time t09 with respect to disconnection on direct current side						

t_{0,1} - releasing time (from switching on current to drop in braking torque to 10% Mnom)

t_{0,9} - braking time (from switching off current to attaining 90% Mnom)

*) Values of releasing and braking times are given as approximations, since they depend on mode of assembly/installation, temperature and power supply.

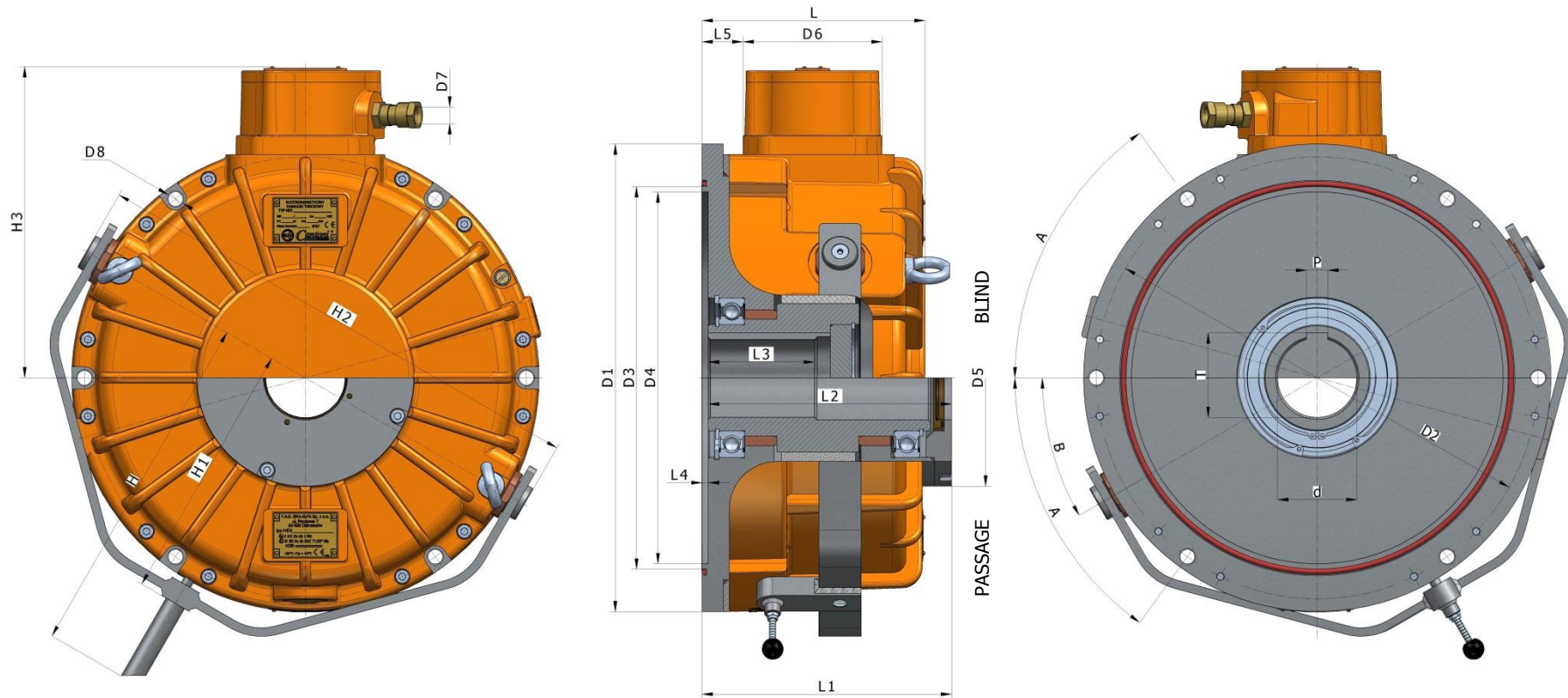

☛ I M2 ☛ II 2G

Type	D1	D2	D3	D4 (H7)	D5	D6	D8	L	L1	L2	L1	L2	L3	L4	L5	H	H1	H2	H3	A	B	d* (H7)	P* (p9)	T*	dmin*	dmax*	Snom.	Smax.
HEX 05	220	200	160	150	118	92	M8	124	161	157	161	157	55	4	21	218	128	247	172	55°	30°	28	8	31,3	20	35	0,3 ^{±0,05}	0,8
HEX 10	247	225	190	180	125	92	M10	133	158	154	158	154	60	4	26	229	139	266	184	60°	30°	35	10	38,3	24	35	0,3 ^{±0,05}	1,0
HEX 15	292	270	200	180	142	92	M10	142	174	169	174	169	65	5	23	288	161	305	206	60°	30°	42	12	45,3	30	42	0,5 ^{±0,05}	1,1
HEX 25	330	305	250	230	142	131	M12	160	182	177	210	205	75	5	17	336	184	353	246	60°	30°	42	12	45,3	34	42	0,5 ^{±0,05}	1,1
HEX 50	370	350	320	300	185	131	M12	174	206	200	236	230	85	6	30	456	207	397	261	60°	30°	42	12	45,3	35	70	0,5 ^{±0,05}	1,1
HEX 100	425	400	360	350	185	131	M16	194	226	220	256	250	90	6	31	599	237	453	283	60°	20°	55	16	59,3	55	70	0,6 ^{±0,05}	1,1
HEX 160	440	416	360	350	204	131	M16	210	235	229	268	262	100	6	38	707	245	476	293	54°	30°	70	20	74,9	55	75	0,6 ^{±0,10}	1,1

* the size of the prism groove adapted to the diameter of the hole in the sleeve gear in accordance with standard DIN6885

HEX

Mechanical size
05, 10, 15, 25, 50, 100, 160

Explosion-proof version	
⚠ I M2 Ex db [ia] I Mb	
⚠ II 2D Ex tb [ia] IIIC T125°C Db	
⚠ II 2G Ex db [ia] IIB T4 Gb	G
⚠ II 2D Ex tb [ia] IIIC T125°C Db	

Configuration	
Blind	0
Passage	1
Blind + lever	2
Passage + lever	3

Options	
Microswitch KZ (operation monitoring) - base	0
Microswitch KZ + KO (brake lining control) - available on the size of the HEX 25	1

the hole diameter of the sleeve gear d... (H7)	
Terma protection	
Bimetallic	B
Posistor	P
Nominal braking torque [Nm]	
HEX 05	50, 40
HEX 10	100, 80, 60
HEX 15	150, 120
HEX 25	250, 240, 180
HEX 50	500, 420, 360
HEX 100	1000, 900, 800, 700, 600
HEX 160	1600, 1300, 1050

Work voltage	
24, 104, 180 [VDC] - all size of the brake	
230, 400 [VAC] - available on the size from the HEX 25 to 160	

Order example: HEX 15 . 10 . 104 VDC 180 Nm d40 B
 HEX 160G . 11 . 400 VAC 1600 Nm d75 P

After consultation with the producer, there is a possibility to make a special version of the brake takes into account, among others, changes in:

- operating voltage of the brake (max. 225 VDC and max. 400 VAC),
- the hole diameter of the sleeve gear.

The producer reserves the right to modify as a result of developing the product.