

A-A (1:1)

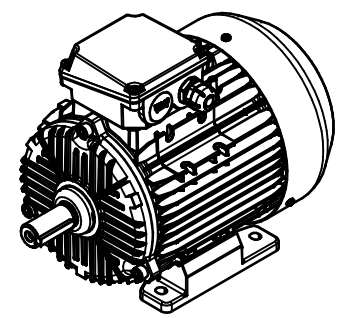

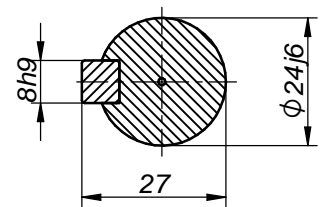

A-A (1:1)

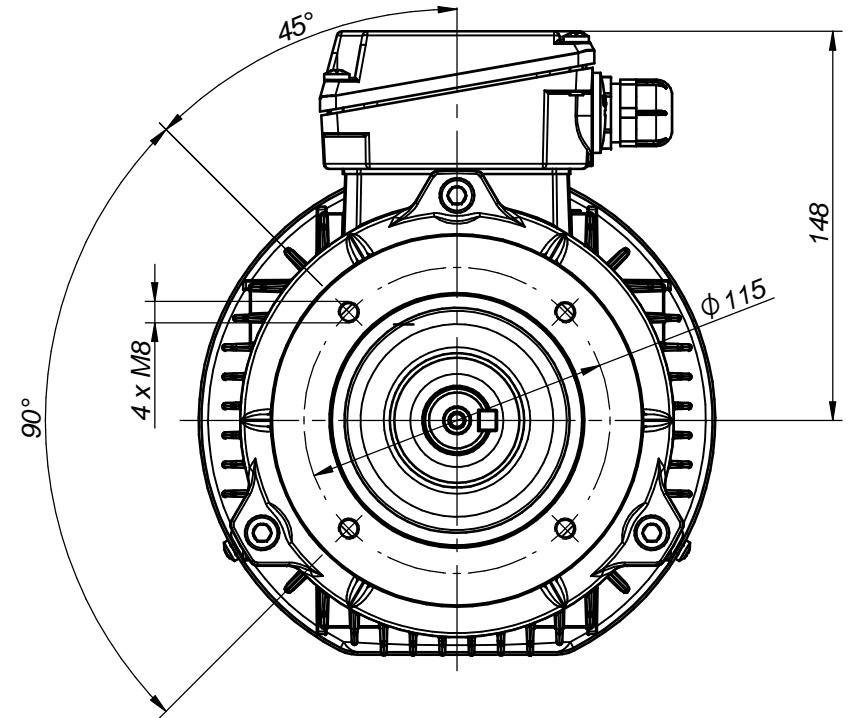
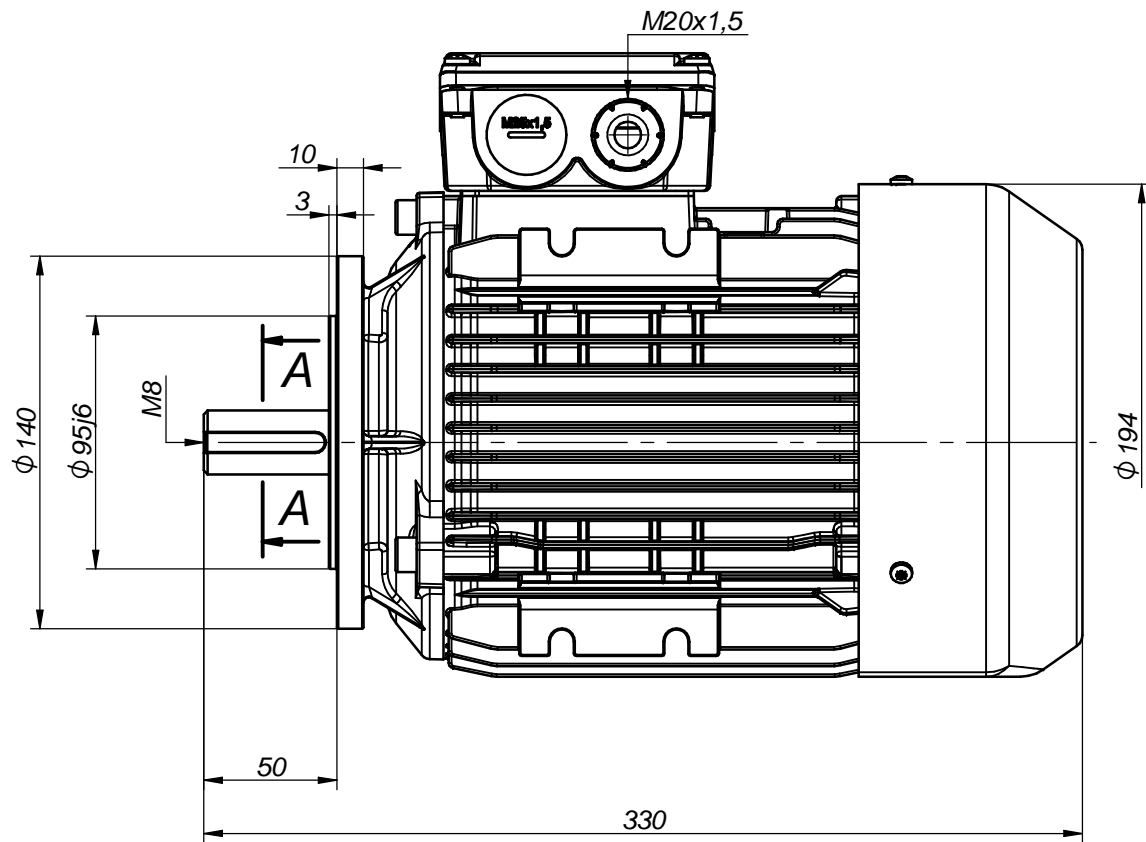
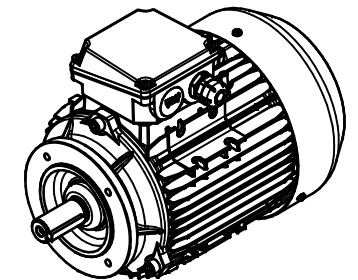
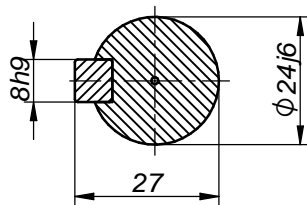

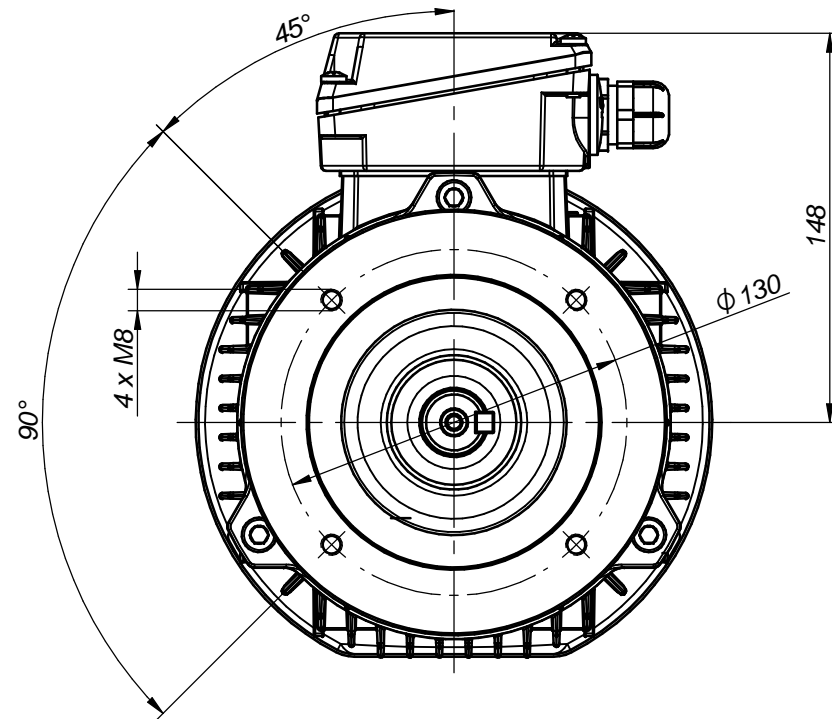
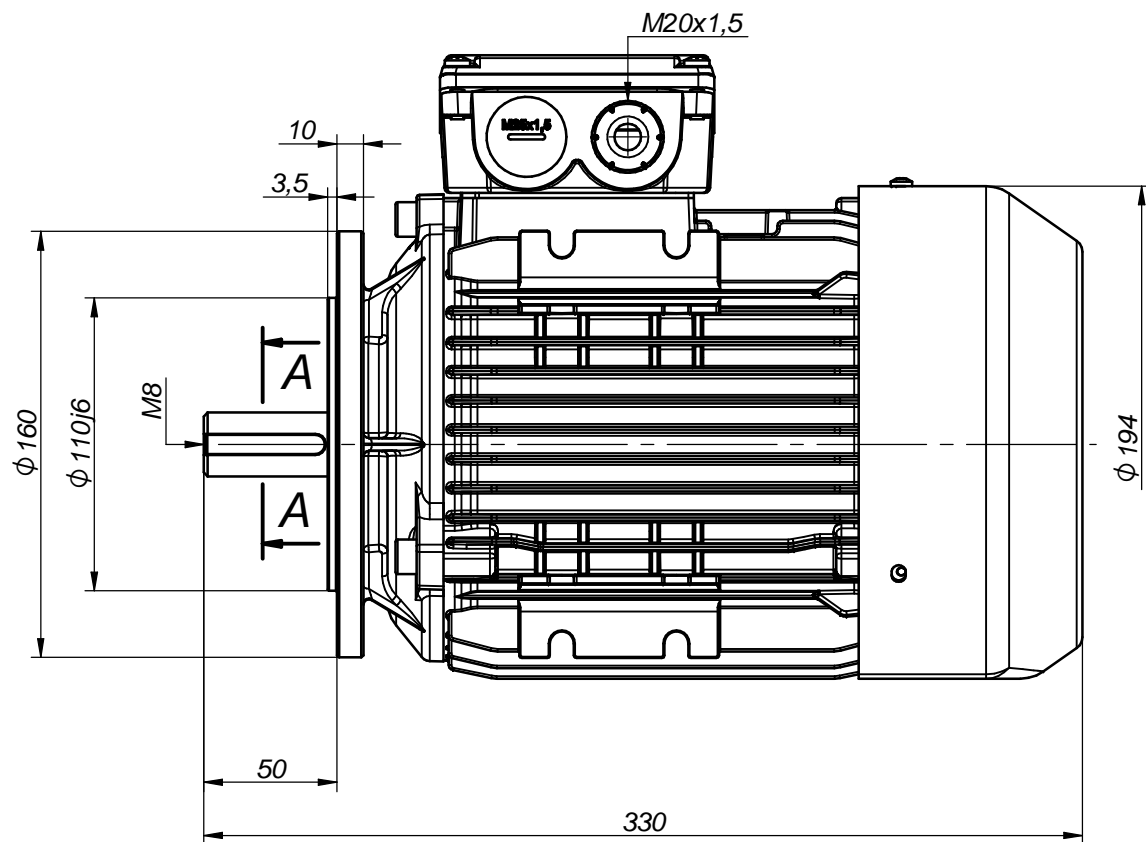

A-A (1:1)

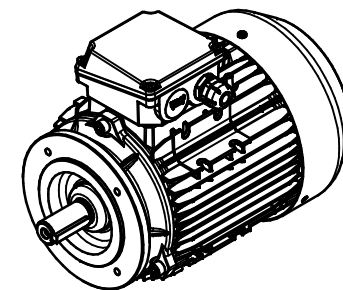
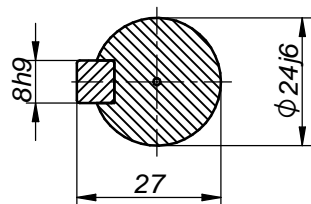

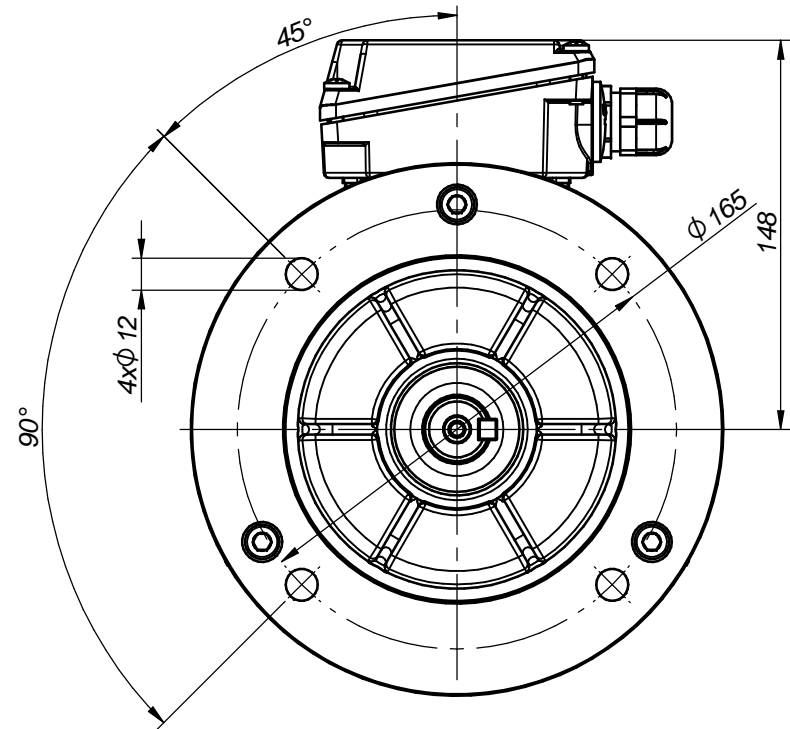
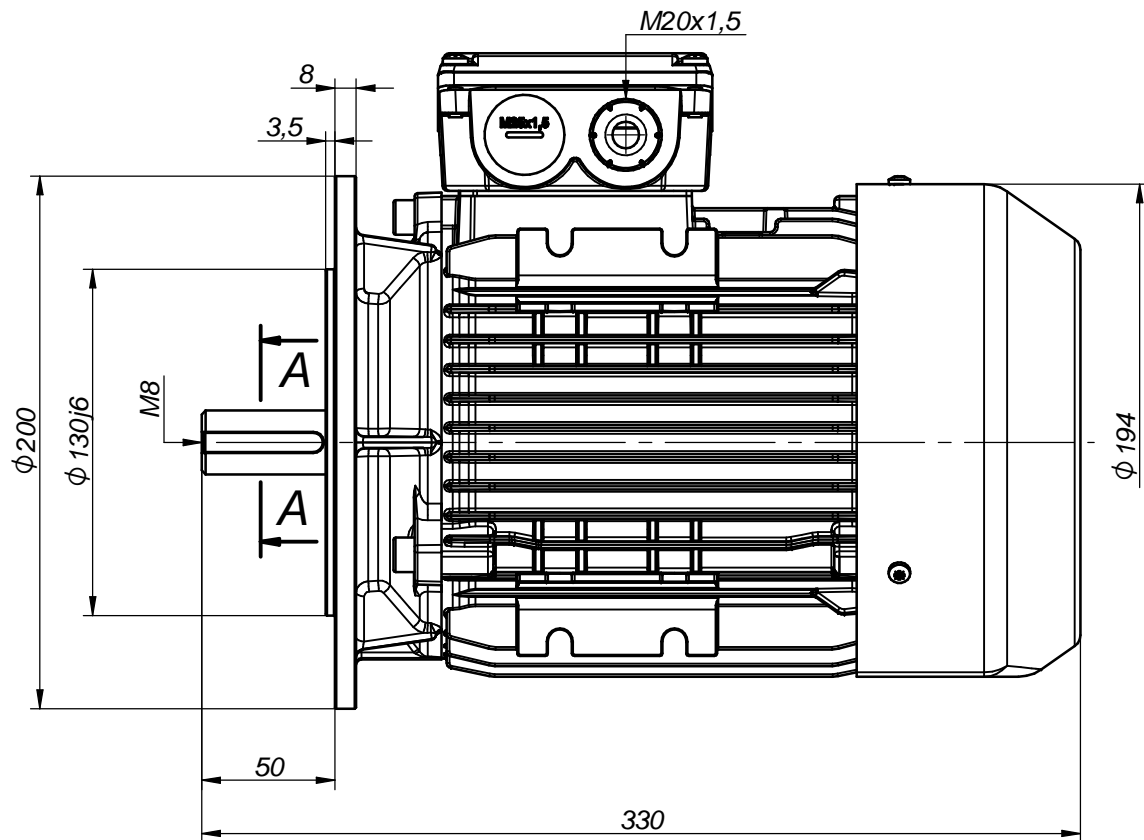

A-A (1:1)

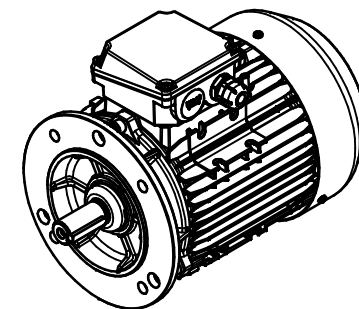
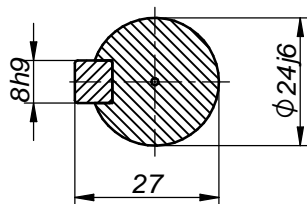

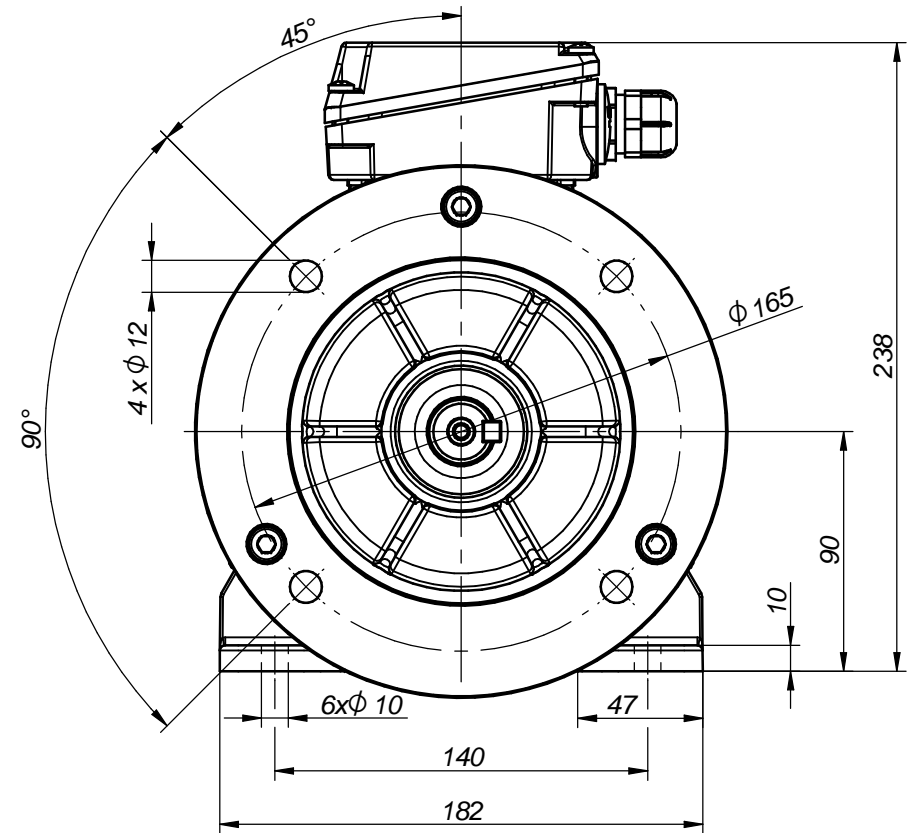
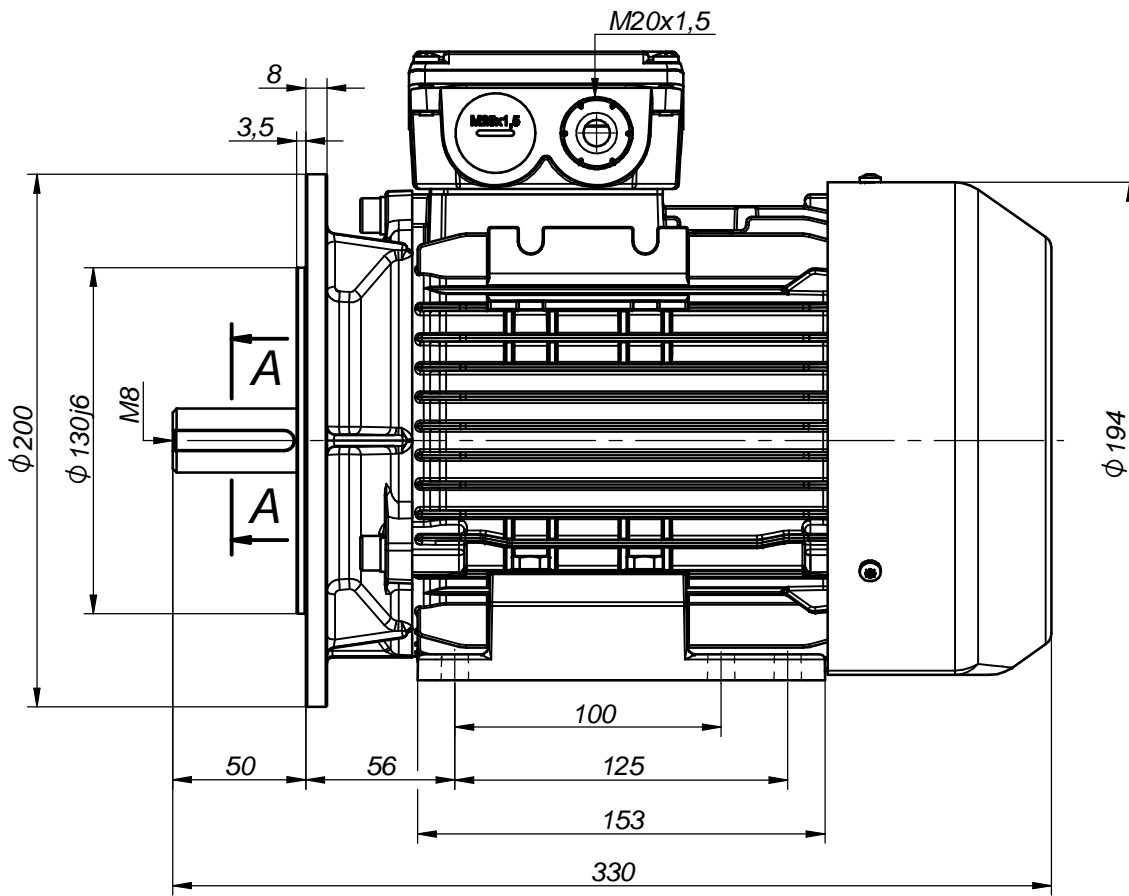

A-A (1:1)

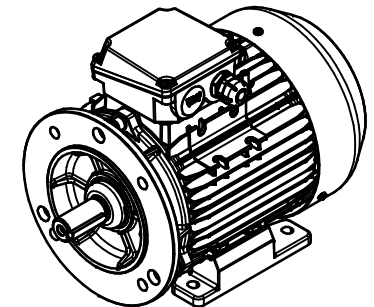
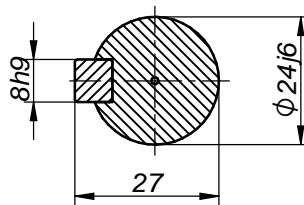

Motor type

**Ex 3SIEL90S2,4,6;L2 – 2G,2D,2G/2D – IMB35**

Drawing no.

**S-161-01-2023**

Scale

**1:2**